

Service Manual

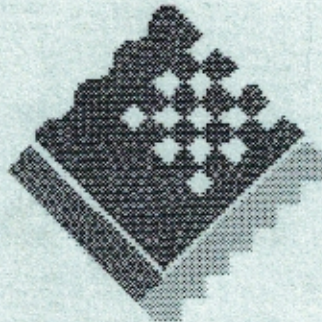

EIZO

NANAO

200-5927-~

ASSY CLR DSPL 29TYPE 31K 2934
NANAO (FST)

(Nanao JPN ~ MS-2934)

CONTENTS

	ABOUT THIS MANUAL	1
I	BEFORE THE SERVICE	I-1
	GENERAL NOTICE	I-1
	HANDLING OF ELECTRIC PARTS	I-2
	HANDLING OF THE CRT	I-3
	HANDLING OF THE LCD PANEL	I-4
	ABOUT SOLDERING WORKS	I-5
II	SERVICE & ADJUSTMENT	II-1
	GENERAL NOTICE	II-1
	NOTICE ABOUT ELECTRICAL CIRCUIT	II-2
	SERVICE & ADJUSTMENT FLOW	II-3
III	MATERIALS FOR SERVICE	III-1
	HOW TO READ THE S/No OF CRT	III-1
	SCREWS & NUT TORQUE LIST	III-6
	SECTION 1 – SPECIFICATION	1-0
	CRT SPECIFICATION	1-1
	ELECTRICAL SPECIFICATIONS	1-3
	DISPLAY	1-4
	DISTORTION	1-5
	ITC PERFORMANCE	1-6
	POWER SUPPLY	1-7
	SIGNAL INPUT	1-8
	RECOMMENDED SIGNAL TIMING CHART	1-9
	ADJUSTMENT SPECIFICATIONS	1-10
	MECHANICAL SPECIFICATIONS	1-14
	AC CORD	1-15
	CONFIGURATION	1-16
	PACKAGING SPECIFICATIONS	1-18
	CONNECTOR SPECIFICATIONS	1-21
	CONDUCTIVE ALUMINIUM FOIL TAPE SPECIFICATIONS	1-23
	CERTIFICATIONS & STANDARDS	1-24
	RELIABILITY & SAFETY	1-25
	OPERATING ENVIRONMENT SPECIFICATIONS	1-26
	PACKAGING SPECIFICATIONS	1-27
	SECTION 2 – ADJUSTMENT	2-0
	ADJUSTMENT CONTROL	2-1
	TOOLS	2-5
	SIGNAL (ANALOG)	2-6
	ADJUSTMENT LOCATION	2-7
	BEFORE ADJUSTMENT	2-9
	ADJUSTMENT	2-10
	SECTION 3 – TROUBLESHOOTING	3-0
	NO SCREEN	3-1
	RASTER APPEARS BUT NO IMAGE	3-3
	SYNC IS NOT CORRECT	3-4

Contents subject to change without notice.

About this manual

This primary service manual is prepared to define the basic repairs or services workflow (open the package ~ repair ~ adjustment ~ inspection ~ packing) of the defective products returned from the user for the smooth and certain repairs and services. Please read and understand this manual before attempting service and service based on the each service manual.

This manual and service manual is prepared to assist service organizations or engineers who are in charge of servicing EIZO products, is not for end users but for those technically oriented service engineers from distributors, dealers, VARs and other wholesalers or retailers who are capable of servicing the unit.

▲ DANGER

It indicates a potentially hazardous situation which, if not avoided, will result in death or serious injury.



It indicates a prohibited action.

▲ WARNING

It indicates a potentially hazardous situation which, if not avoided, could result in death or serious injury.



It indicates a general caution.

▲ CAUTION

It indicates a potentially hazardous situation which, if not avoided, may result in minor or moderate injury and/or property-damage.

I. Before the service

I-1. General Notice

⚠ DANGER

The EIZO products contain high voltage circuit. Only experienced service personnel should perform repairs or service work on high voltage monitors.

When the cabinet of the product is removed and the product is operating, there is a risk of an electric shock hazard.

⚠ WARNING

1) **Unplug the power cord before servicing.**

Operation of the monitor or peripheral with the cabinet removed involves a shock hazard or may result in a damage of the circuit. Ensure the power cord is disconnected before removing the cabinet and replacing any parts in the unit.

2) **Connect the earth lead of the power cord with the ground.**

Securely connect the earth lead of the power cord of the products and the measuring equipment. There is a risk of the electric shock hazard or damage.



3) **Do not wear any metal or accessories.**

There is a risk of an electric shock.



Perform the inspection of the measuring equipment before service work.

Before starting daily service work, perform the inspection of the measuring equipment and record its results.

I-2. Handling of electric parts

▲WARNING

Replace only with the exact factory recommended spare parts.

The use of unauthorized substitute parts may cause an electric shock, damage to the monitor, or may exceed the specified X-ray radiation. Please refer to the below notice* regarding the handling and keeping method of the electric parts.

- Safety related parts Parts List : "S" Circuit Diagram : "△"
- X-ray related parts Parts List : "X" Circuit Diagram : "★"
- Anti-static related parts Parts List : "A"
- Moisture protection related parts Parts List : "M"

*Notice at handling and keeping the electric parts

1. Anti-static related parts

In order not to damage or lower the performance of the transistor or IC by the electrostatic from the body, wear the wrist strap when you handle the anti-static semiconductor.

The usage of the wrist strap

- (1) wear the wrist strap tightly at the wrist.(right or left)
- (2) Connect the earth and alligator clip.

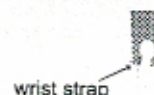

connect to the earth



2. Moisture protection related parts

1) unopened

Handle with care in order not to damage or pick with the sharp edged tool. The SMD stocker (moisture-proof depository) is recommended for the keeping. The normal temperature (below 30 °C) and humidity (below 70 %) is also acceptable if it is packed with moisture-proof method. The keeping term is max one year. When using the moisture protection parts, confirm the silica-gel enclosed with the parts shows blue. If it is absorbed, it shows pink or clear.

2) opened

Once it is opened, keeping in the SMD stocker is recommendable. The keeping term in the stocker is maximum 6 months. If the SMD stocker is not available, the parts must be used within 4 days under the normal temperature (below 30 °C) and humidity (below 70 %).

3) F.B.T and keeping term instructed parts from the maker

They must be kept as the following condition in order not to lower the performance of the parts due to the long-term stock. The parts which expire the keeping limit must be disposed.

Parts	Packing	Keeping terms (after the production)
F.B.T (or the PCB Unit which equips the F.B.T)	Normal	15 months
	(Moisture protection packing moisture-proof aluminum bag with enclosing silica-gel)	8 years
Keeping term instructed parts	Normal /Special	Due to maker's instruction* *Instructed by updating this manual.

I-3. Handling of the CRT

⚠ WARNING

- 1) **Replace with a CRT of the same type number for continued safety.**

The CRT used in the monitor employs integral implosion protection. If the CRT is replaced with a different type, it will result in an improper circuit function, exceed the specified Safety Standards range, or affect the picture quality guaranteed in the specifications.

- 2) **Take care not to scratch the coating of the Degauss Coil.**



Degauss Coil circuit is on the primary voltage line. It can result in a hazardous fire or electric shock. Follow the instructions below.*

-
- *1) The Degauss Coil has a current of 5~10A. When the coating of the Degauss Coil is damaged and the Coil directly touches the chassis or screws, the chassis voltage will become the same as the primary voltage line. This can result in hazardous danger as follows.

- (1) Electric Shock
- (2) Short (Current Leakage)
- (3) Degauss does not work
- (4) Circuit Damage
- (5) Damage of connected computers or peripherals

- 2) After the work is done, make certain that there are no damage on the coating of the Degauss Coil.
 - (1) The Degauss Coil is set in the specified place.
 - (2) The Degauss Coil does not touch the shields, screws, or other conductive sharp edges.
 - (3) The Degauss Coil is not pushed or pressed.
- 3) To prevent these hazards, carry out the "Safety Test" on the beginning of this manual.
 - (1) Earth Continuity Test
 - (2) Withstanding Voltage Test

⚠ CAUTION



Do not lift the CRT by the neck.

The neck of the CRT is not firm enough to hold the entire CRT. Hold the CRT under your arms when lifting it. In case the CRT is dropped, it could result in injury.



I-4 Handling of the LCD panel

When servicing LCD, follow the instructions below for anti-static measures because LCD panel is weak for static electricity.

1. Places for Servicing

- 1) Conductive floor (Recommended resistance value: $1 \times 10^5 - 1 \times 10^8 \Omega$)
*We recommend you to clean and measure the floor twice a year and wax (conductive) once a year.
- 2) Conductive mat (Recommended resistance value: $1 \times 10^6 - 1 \times 10^8 \Omega$)
- 3) Anti-static parts box (Recommended resistance value: $1 \times 10^5 - 1 \times 10^8 \Omega$)
- 4) Ion blower
*Recommended method: AC
*Control the speed of the blower. This may cause an unbalance of ion.
*The ion blower may deteriorate due to dirt or moisture if it is used for long periods.
Please clean it once a week.

Keep a space of 10~15 cm between the ion blower and the LCD Panel.

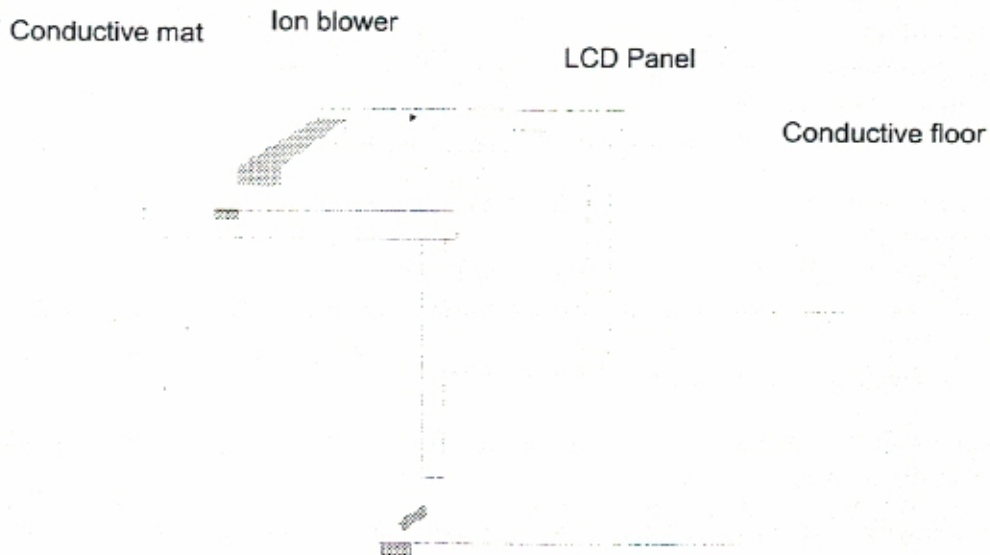

Securely connect to the GND.

2. Wear for Servicing

- 1) Wrist strap (Recommended resistance value: $5 \times 10^5 - 1 \times 10^7 \Omega$)

▲WARNING

Use a wrist strap with $5 \times 10^5 - 1 \times 10^7$ resistance for protection.

When using a wrist strap without resistance, there is a risk of an electric shock.

- 2) Conductive shoes (Recommended resistance value: $1 \times 10^5 - 1 \times 10^8 \Omega$)
* 1×10^6 or less is desirable.
- 3) Anti-static wear

3 Servicing Environment

Keep the room temperature at 18-24°C and the humidity between 50-80% RH.

I-5 About Soldering works

▲CAUTION



- 2) **Do not press the FS jumper with soldering iron for long hours.**

This will cause melt of solder on the PCB parts side and connection with pattern may be incomplete. After soldering, check the solder part on the other side.

The soldering conditions are as follows: In order to keep the performance of the iron, perform the daily or periodical inspection of the iron. (check the point temperature of the iron is 340~375°C.)

Solder temperature		340~375°C
Solder Iron Watt	chip	Within 30W
	Discrete	30~60W
	Radiator	50~100W
Working time	Tip/discrete	Within 3 seconds
	Radiator	Within 6 seconds
Solder kind	Sn 60% or Sn 63% A class wire solder	
	Tip	Below $\phi 0.6\text{mm}$
	Discrete	Below $\phi 1.2\text{mm}$
Recommended Iron		HAKKO Corp. Mach 1 No.921
		HOZAN HS-25

II. Service and Adjustment

II-1. General Notice

▲ DANGER

When adjusting or servicing the PCB with the power switch ON, securely connect the shield part of the ASSY CRT to the GND on the PCB (Secondary Radiator, etc.) with leads before turning the power switch on.

If not, the high voltage put into the monitor causes unstability of the external earth. This will result in a serious electric shock or damage.

▲ WARNING



- 1) **Do not connect or disconnect any wires or connectors while the products is in operation.**

It may result in damage to the circuit or may cause an electric shock.



- 2) **Do not short any portion of circuit while the product is in operation.**

This will cause smoke, electric shock or damage to the transistors, ICs or other parts or circuit in the unit. (*Excluding the Adjustments only when specified.)



- 3) **Do not change the original design of the product.**

This will cause smoke, electric shock or damage to the circuit.

- 4) **Use 2 pin power plug of the Digital voltage meter.**

Otherwise, an electric shock, damage to the circuit or breaker-down may occur

▲ CAUTION



- Do not touch the sharp edge of the chassis.**

It may result in injury.

II-2. Notice about Electrical Circuit

⚠ WARNING



- 1) **Do not touch the +B Voltage and High Voltage terminals inside the monitor.**

If carelessly contacted, it can cause serious shock or result in damage to the monitor.

- 2) **Check the adjustment VRs are adjusted within the specifications range and securely locked together with silicon rubber as instructed in the service manual.**

The VRs should be adjusted and then sealed with silicone rubber as instructed in the service manual. If the voltage is out of the specifications range, the X-ray radiation may increase or may cause damage to the monitor.



- 3) **Do not operate with a High Voltage level exceeding the specified range in the service manual.**

Failures in the High Voltage Adjustment can increase X-ray radiation or damage to the circuit. To check for the presence of High Voltage, use an accurate high impedance High Voltage Meter connected between the Anode Button and the secondary earth. It may cause a rise in the voltage when the Power Supply Voltage is out of the specifications range.

- 4) **Turn off the power switch and then connect the high voltage probe.**

Adjusting High Voltage with the monitor operating is extremely dangerous. An electric shock may occur.

- 5) **When checking wave on the primary voltage line, use the 2-pin power plug of oscilloscope. Do not connect GND on the primary circuit and GND on the secondary circuit (chassis).**

If not, this may cause electric shock, damage to the circuit or breaker-down.

- 6) **Do not check on the primary and secondary voltage line with same oscilloscope at the same time. If necessary, connect the Isolation Trans for the power of monitor.**

This may cause an electric shock or damage to the circuit.



- 7) **Disconnect the Power Cord, and completely remove static charge before taking off the Anode Cap.**

When discharging high voltage, be sure to disconnect the power cord.

Connect a 10kΩ resistor (1W and over) and a insulator wire (such as a test probe) between CRT dag and the Anode Button.

If the High Voltage is not removed, you will get an electric shock by touching the Anode Cap area.

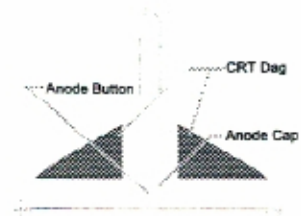
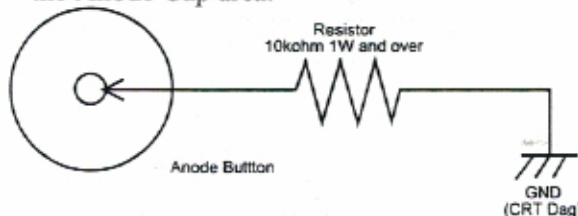

II-3. Service and adjustment Flow

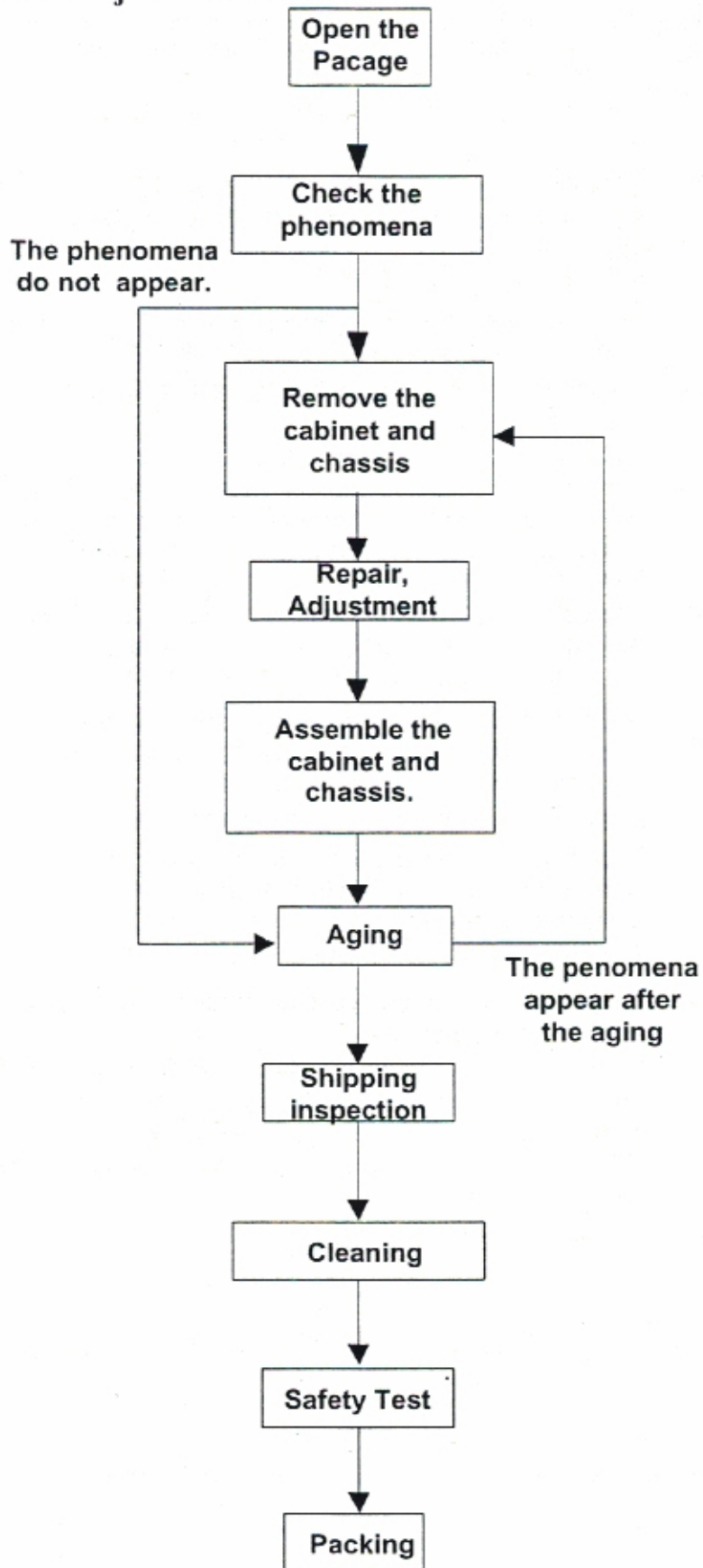

1. Open the package

	Works	Controlled Item	Equipment
1.	Open the returned product from the user.	Packing Case	Crane
2.	Check the enclosed accessories in order not to miss at the shipment after the repair.	Enclosed accessories, RMA No. S/N	

2. Check the phenomena

	Works	Controlled Item	Equipment
1.	Check the phenomena of the returned products.	Phenomena, RMA No.	Signal Generator, Brightness meter, Scale, loupe
2.	When the phenomena do not appear, go to "4. Aging".		

3. Repair/Adjustment

	Works	Controlled Item	Equipment
1.	Remove the cabinet and chassis referring to the service manual.		Electric driver
2.	Perform the analysis, repair and adjustment to the confirmed phenomena.	Soldering iron temperature, wrist strap, parts handling and keeping	Signal generator, brightness meter, scale, loupe, soldering iron, tester, oscilloscope, digital multi meter, high voltage meter, PC, frequency counter, high voltage meter
3.	Assemble after the repair and adjustment works are finished. Regarding the screw tightening torque or tightening location, refer to the attached materials III-2.	Screw tightening torque	Electric driver torque driver

4. Aging (flow)

- (1) Image quality claim
- (2) Another claim

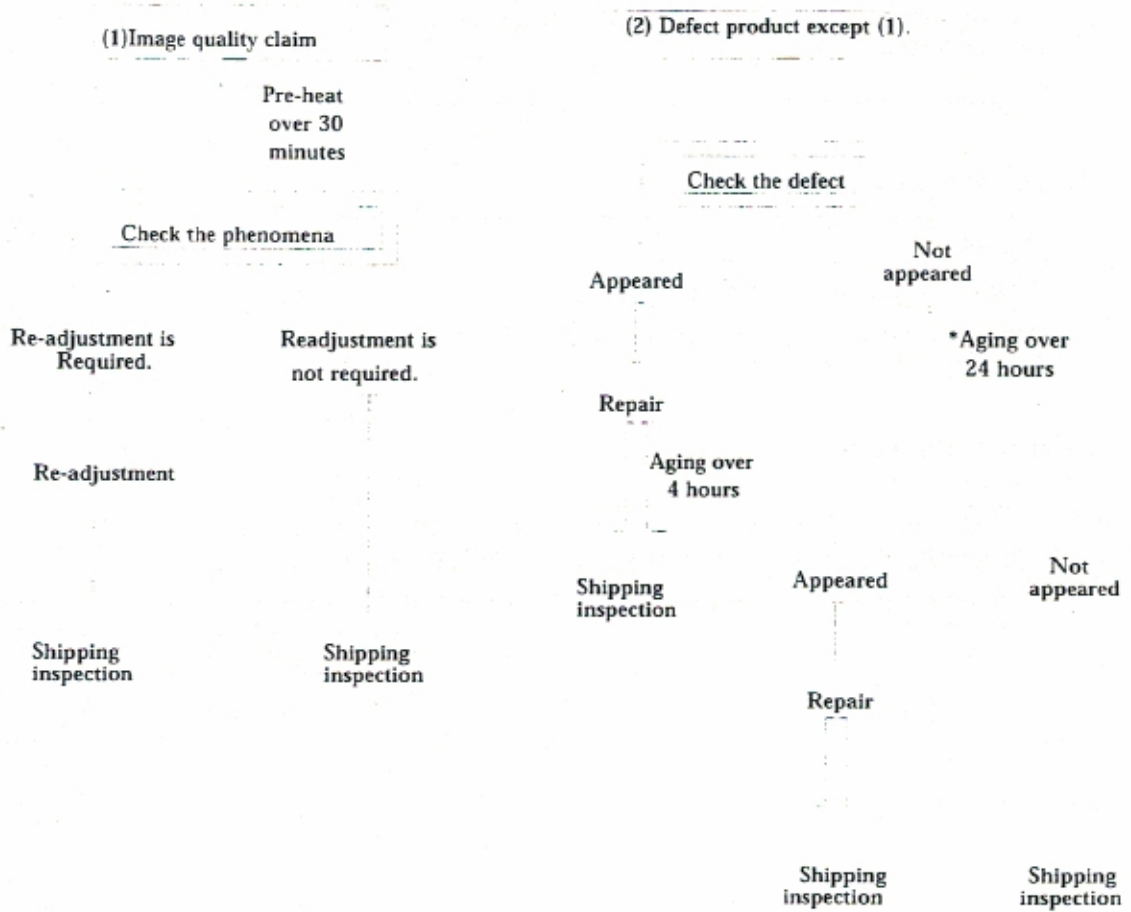

	Notice at aging	Controlled Item	Equipment
1.	Input para-signal-generator, PC or signal generator during the aging.	Aging hours	Para-signal generator, PC, Signal Distributor
2.	The temperature is from 25C~45C. Regarding the products that can perform aging at the same condition with user (the internal shield or external cabinet are equipped.) the temperature control is not necessary.		
3.	The defective and damaged product due to the falling, etc. requires over 50 hours over aging.		
4.	Image quality adjustment, disconnecting, repair or the cabinet, etc. do not need aging. When the image quality adjustment, the pre-heat is needed before the phenomena confirmation for 30 minutes over.		
*	If the phenomena do not appear after 24 hours aging, contact with the user and decide the handling of it.		

5. Shipping Inspection

	Works	Controlled Item	Equipment															
1.	<p>Perform the following shipping inspection and confirm that the repaired product fulfills the specification. If it does not fulfill, repair or adjust again.</p> <table border="1"> <thead> <tr> <th></th> <th>Inspection</th> <th>Judgement standard</th> </tr> </thead> <tbody> <tr> <td>Image quality</td> <td>Brightness/Focus/ Distortion/Size, Purity/ Convergence/White Balance, Uniformity</td> <td>Refer to the each service manual</td> </tr> <tr> <td>Function Test</td> <td>Check the Adjustment function of VR or SW, etc.</td> <td>Operates correctly.</td> </tr> <tr> <td>PCB/ Mechanical Test</td> <td>Check the condition of soldering, parts, pattern, wiring, chassis.</td> <td>There is no leg slip soldering, non-soldering, missing parts, pattern peeling or missing screws</td> </tr> <tr> <td>Shock test</td> <td>Shock parts, PCB or chassis and check the image quality and function.</td> <td>The shock to the product does not affect to the image quality or function of the product.</td> </tr> </tbody> </table>		Inspection	Judgement standard	Image quality	Brightness/Focus/ Distortion/Size, Purity/ Convergence/White Balance, Uniformity	Refer to the each service manual	Function Test	Check the Adjustment function of VR or SW, etc.	Operates correctly.	PCB/ Mechanical Test	Check the condition of soldering, parts, pattern, wiring, chassis.	There is no leg slip soldering, non-soldering, missing parts, pattern peeling or missing screws	Shock test	Shock parts, PCB or chassis and check the image quality and function.	The shock to the product does not affect to the image quality or function of the product.	Proofread of the each meter, inspection before the work	PC, Signal Generator, Brightness meter, Scale Loupe
	Inspection	Judgement standard																
Image quality	Brightness/Focus/ Distortion/Size, Purity/ Convergence/White Balance, Uniformity	Refer to the each service manual																
Function Test	Check the Adjustment function of VR or SW, etc.	Operates correctly.																
PCB/ Mechanical Test	Check the condition of soldering, parts, pattern, wiring, chassis.	There is no leg slip soldering, non-soldering, missing parts, pattern peeling or missing screws																
Shock test	Shock parts, PCB or chassis and check the image quality and function.	The shock to the product does not affect to the image quality or function of the product.																

6. Cleaning

	Works	Controlled Item	Equipment
1.	Clean the outer dirt of the returned products.	Scratch, dirt	Gauze, AR cloth, ethanol, isopropyl ethanol

7. Safety Test

⚠ DANGER

When any portion of the chassis is short-circuit caused by a leakage of primary voltage line, the conductive area may become high voltage which can result in an electric shock or other hazardous danger.

⚠ WARNING

- 1) **Testing equipment should be isolated by putting an insulating board in between.**

When the back cabinet of the monitor is removed and the monitor is operating, there is a risk of an electric shock.

- 2) **Keep people away during the test.**

When the back cabinet of the monitor is removed and the monitor is operating, there is a risk of an electric shock.



- 3) **Do not wear any metal or accessories.**

There is a risk of an electric shock when the circuit is shorted.

7-1 Earth continuity Test

(All model of the monitor, some peripherals which has the insulated transformer and earth function)

Works	Controlled Item	Equipment
1. Connect the Test AC cord to the product at the shipping stage.	Current, resistance	Test equipment for earth continuity Test
2. Impress AC 25A between the conductive chassis and the earth terminal of the AC Power cord for 1.5~2.5 seconds. Press the test button of the equipment and check the OHM meter of the test equipment show below 0.1OHM.(the OHM meter which indicates the resistance does not enter in the red zone.		
3. If it exceeds 0.1OHM, the product is distinguished as the rejected one. Reconfirm the earth lead connection of the product and test method.		
4. After the test, check the image quality and function.		

7-2 Withstanding voltage check

(All model of the monitor, some peripherals which has the insulated transformer with AC power supply)

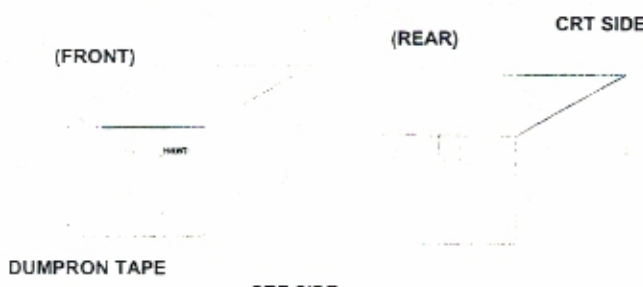

	Works	Controlled Item	Equipment													
1.	Connect the Test AC cord to the product at the shipping stage.	Voltage, Current	Test equipment for withstanding voltage check													
2.	Impress the AC voltage (100~120V: 1200VAC, 220~240VAC: 1500VAC) between a conductive chassis and the line of the AC cord for 1~2 seconds when the Main Power SW is ON. Press the test button of the equipment and confirm if it should not be NG.															
	<table border="1"> <thead> <tr> <th>Model</th> <th>voltage</th> <th>Current</th> </tr> </thead> <tbody> <tr> <td rowspan="2">CRT display, LCD display (except L23, L34)</td> <td>1500VAC</td> <td>25mA</td> </tr> <tr> <td>1200VAC</td> <td>20mA</td> </tr> <tr> <td rowspan="2">LCD display L23, L34</td> <td>1500VAC</td> <td>5mA</td> </tr> <tr> <td>1200VAC</td> <td>5mA</td> </tr> </tbody> </table>			Model	voltage	Current	CRT display, LCD display (except L23, L34)	1500VAC	25mA	1200VAC	20mA	LCD display L23, L34	1500VAC	5mA	1200VAC	5mA
Model	voltage			Current												
CRT display, LCD display (except L23, L34)	1500VAC			25mA												
	1200VAC	20mA														
LCD display L23, L34	1500VAC	5mA														
	1200VAC	5mA														
3.	If it is broken down, the product should be distinguished as the rejected one. Reconfirm the internal condition of the product and test method.															
4.	After the test, check the image quality and function.															

8. Packing

	Works	Controlled Item	Equipment																		
1	Cover new packing bag on the product.																				
2.	Pack the enclosed accessories from the user.	Enclosed accessories																			
3.	Confirm that product name and S/N on the Name-Plate is same in order not to mis-shipment.	Model Name, S/N																			
4.	Equip the cushion (If it damaged badly, replace with new one.) (A) Fix the bottom of the cushion with plain dumpron tape (50mm width) (small model like F550-iW) (B)Fasten with P.P Band (Large model likeT660I or T560I, etc.) (C) Confirm the direction and location when 4 separated cushion. Are equipped. (D)Others	Cushion																			
5.	<p>Put the product in the packing case with noting its direction. (Packing case other than EIZO's or badly damaged one should be replaced with new one)</p>  <p>[How to put the dampron tape at packing]</p> <table border="1"> <thead> <tr> <th></th> <th>Model</th> <th>Tape (Width)</th> <th>way</th> </tr> </thead> <tbody> <tr> <td rowspan="2">Bottom</td> <td>20" larger</td> <td>00N08071A3 (50mm)</td> <td>H</td> </tr> <tr> <td>19" smaller, LCD, Peripheral</td> <td>00N08071A5 (75mm)</td> <td>I</td> </tr> <tr> <td rowspan="2">Top</td> <td>20"larger</td> <td>00N08071A3 (50mm)</td> <td>I</td> </tr> <tr> <td>19" smaller, LCD, Peripheral</td> <td>00N08071A5 (75mm)</td> <td>I</td> </tr> </tbody> </table>		Model	Tape (Width)	way	Bottom	20" larger	00N08071A3 (50mm)	H	19" smaller, LCD, Peripheral	00N08071A5 (75mm)	I	Top	20"larger	00N08071A3 (50mm)	I	19" smaller, LCD, Peripheral	00N08071A5 (75mm)	I	Dampron tape	
	Model	Tape (Width)	way																		
Bottom	20" larger	00N08071A3 (50mm)	H																		
	19" smaller, LCD, Peripheral	00N08071A5 (75mm)	I																		
Top	20"larger	00N08071A3 (50mm)	I																		
	19" smaller, LCD, Peripheral	00N08071A5 (75mm)	I																		



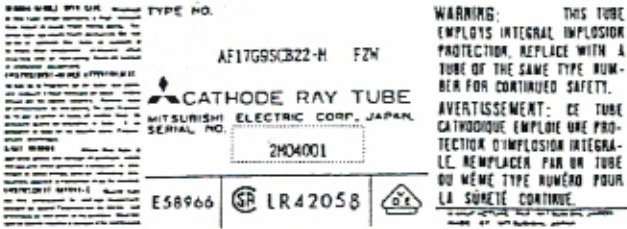
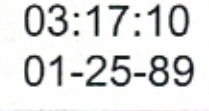
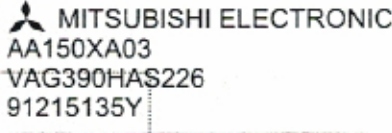

III. Materials for Service

III-1 How to read the Serial Number of CRT and LCD Panel Type

Manufacturer	Type	Sample
<p>MITSUBISHI</p> <p>All Display Tubes & TV Tubes excluding A63LCC11X</p>		 <p>[Type] AF17G9SCB22-M [S/N] 2M04001 year 1992 Production month M = December (Starting from A~M excluding "I")</p>
	<p>only for A63LCC11X</p>	 <p>[S/N] 03:17:10 time 3:17:10 (24Hr) 01-25-89 date - 1989. 1(January). 25</p>
	<p>LCD Panel</p>	 <p>[Type] [S/N] _____ 15135Y year 9 Production week 12</p>
<p>HITACHI</p>		 <p>[Type] M51KHE180X06 [S/N] m____000000 year 3 Production M = December (Starting from A~M excluding "I")</p>

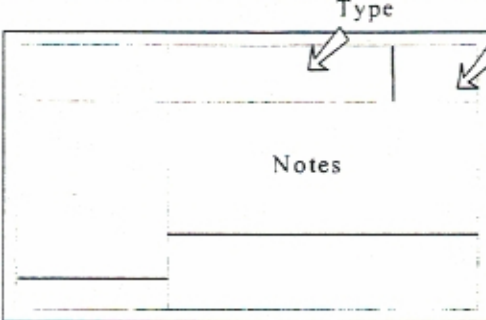
Manufacturer		Sample
TOSHIBA		<p>TOSHIBA E2817B4-SDAS (C7) (L3)</p> <p>SP 1930477 337164 SA 7K23 0A</p> <p>CAUTION: HIGH-VOLTAGE PICTURE TUBE IS DANGEROUS TO HANDLE. REFER TO QUALIFIED SERVICE PERSONNEL. DO NOT ATTEMPT TO SEPARATE YOUR PICTURE TUBE FROM THE INTEGRAL PICTURE TUBE ASSEMBLY.</p> <p>WARNING: THIS PICTURE TUBE EMPLOYS INTEGRAL IMPLOSION PROTECTION. REPLACE WITH A TUBE OF THE SAME TYPE NUMBER FOR CONTINUED SAFETY.</p> <p>AVERTISSEMENT: CE TUBE CATHODIQUE EMPLOIE UNE PROTECTION ANTI-IMPLOSION INTEGRALE. REMPLACEZ PAR UN TUBE DU MEME TYPE NUMERO POUR LA SURETE CONTINUE.</p> <p>[Type] 0A</p> <p>[S/N] 7K23</p> <p>year 0 Production</p> <p>A = January (Starting from A~L)</p>
olor (17)		<p>TOSHIBA M41KZZ22XX 3D (D1G1)</p> <p>93 03164 027317 0</p> <p>CAUTION: HIGH-VOLTAGE PICTURE TUBE IS DANGEROUS TO HANDLE. REFER TO QUALIFIED SERVICE PERSONNEL. DO NOT ATTEMPT TO SEPARATE YOUR PICTURE TUBE FROM THE INTEGRAL PICTURE TUBE ASSEMBLY.</p> <p>WARNING: THIS PICTURE TUBE EMPLOYS INTEGRAL IMPLOSION PROTECTION. REPLACE WITH A TUBE OF THE SAME TYPE NUMBER FOR CONTINUED SAFETY.</p> <p>AVERTISSEMENT: CE TUBE CATHODIQUE EMPLOIE UNE PROTECTION ANTI-IMPLOSION INTEGRALE. REMPLACEZ PAR UN TUBE DU MEME TYPE NUMERO POUR LA SURETE CONTINUE.</p> <p>SAFETY INFORMATION: THIS PICTURE TUBE EMPLOYS INTEGRAL IMPLOSION PROTECTION. REPLACE WITH A TUBE OF THE SAME TYPE NUMBER FOR CONTINUED SAFETY.</p> <p>[Type] M41KZZ22XX (D1G1)</p> <p>[S/N] Marked on the base part of the CRT neck (MA-1786/1795 13 digit numbers at right upper</p> <p>[Production] 3D 1993</p> <p>month D</p>
Color (15")		<p>TOSHIBA M36LGE27XX03 9604 100364</p> <p>96 03164 027317 0</p> <p>CAUTION: HIGH-VOLTAGE PICTURE TUBE IS DANGEROUS TO HANDLE. REFER TO QUALIFIED SERVICE PERSONNEL. DO NOT ATTEMPT TO SEPARATE YOUR PICTURE TUBE FROM THE INTEGRAL PICTURE TUBE ASSEMBLY.</p> <p>WARNING: THIS PICTURE TUBE EMPLOYS INTEGRAL IMPLOSION PROTECTION. REPLACE WITH A TUBE OF THE SAME TYPE NUMBER FOR CONTINUED SAFETY.</p> <p>AVERTISSEMENT: CE TUBE CATHODIQUE EMPLOIE UNE PROTECTION ANTI-IMPLOSION INTEGRALE. REMPLACEZ PAR UN TUBE DU MEME TYPE NUMERO POUR LA SURETE CONTINUE.</p> <p>[Type] M36LGE27XX03</p> <p>[S/N] 100364</p> <p>[Production] 9604</p> <p>year 1996 Production</p> <p>week 04 = week 4</p>

Manufacturer	Type	Sample
TOSHIBA	LCD Panel	<p style="text-align: center;">TOSHIBA MADE IN JAPAN</p> <p>LTM15C151A </p> <p style="text-align: center;">* 6 6 C 8 L 1 0 0 6 5 2 *</p> <p>[S/N] 66C8L100652 year 1998 Production month L=December (Starting from A~L)</p>
SHARP	LCD Panel	<p style="text-align: center;">SHARP LQ14X03 8X T00004 MADE IN JAPAN</p> <p>[Type] LQ14X03 [S/N] 8X T00004 year 1998 Production month X = October (Starting from 1~9(Jan.~Sep.) X(Oct.), Y(Nov.), Z(Dec.))</p>
IBM	LCD Panel (2 labels on the rear)	<p style="text-align: right;">P/N 25L779C IBM EC F21755 S/N 800001 ITSX94N1</p> <p style="text-align: center;">OGJ800001</p> <p style="text-align: center;">99/48</p> <p>[S/N] 800001 year 1999 Production week week 48 Production</p>
HITACHI	LCD Panel	<p style="text-align: center;">HITACHI TX46D12VCOCAB</p> <p style="text-align: right;">WARNING HIGH VOLTAGE</p> <p style="text-align: center;">9033H 00001 MADE IN JAPAN</p> <p>[S/N] 9033H 00001 year 1999 Production month 03 = March (01~12 <Jan.~Dec.> week 3 = 15th ~21st. (1st~7th:1, 8th~14th: 2, 15th~21st:3. 22nd~28th: 4, 29th~31st: 5) (00001) = conductive number</p>

Manufacturer	Type	Sample
MATSUSHITA (PANASONIC)	All	<div style="text-align: center;">  </div> <p>[S/N] Shipping No. <u>17</u> year 1991 Production month <u>7</u> = July (1~0 = Jan~Oct, N=Nov, D=Dec)</p>
NEC	All	<p>COLOR DISPLAY TUBE M41LQI15XX44 WARNING: THIS PRODUCT USES HIGH VOLTAGE INTERNAL ELECTRICAL PARTS. REPLACE WITH A TUBE OF THE SAME TYPE DESIGN FOR COMBINED SAFETY.</p> <p>AVERTISSEMENT: CE DESSUS APPAREIL EMPLOIE UNE INSTAURATION EN HAUTE TENSION. REMPLEZER PAR UN TUBE DE MEME TYPE SERVIRZ POUR LA SECURE OPERATION.</p> <p>NEC Corporation Kariya-shi, Aichi Prefecture, Japan Phone: 0564-21-1111 (10 lines)</p> <p>  </p> <p>WARNING: SUBSTANTIAL RISK OF EYE DAMAGE TO HANDLE ITEMS BELONGING TO QUALIFIED SERVICE PERSONNEL.</p> <p>FRONT WARNING: When passing tube to operator of your TV set, please tell them warning message is printed on glass panel. Please provide instructions, special tools, and safety glasses.</p> <p>NEC Corporation  x</p> <p>[Type] M41LQI15XX44 [S/N] 610 10001 year 1996 Production month <u>10</u> = October (1~12 = Jan.~Dec.)</p>

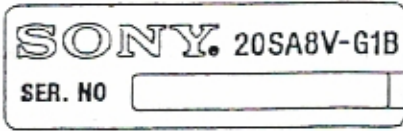
Manufacturer	Type	Sample
SONY	14FGES	[S/N] 2 0614 12345 year 1992 Production date 0614 = June 14
	19TKC	 <p>S/N 039905035085 S</p> <p>Year 1999 Production Date 0503 = May 3 S/N 5085S (Consecutive number)</p>
	17SA 20SA	 <p>[Type] 20SA8V-G1B [S/N] consecutive number</p>

III-2 Screw and nut torque List

1. The unit of the torque in the list----- kgf-cm
2. The torque value is common to mechanical screw and tap-tight screw.
3. The above list is applied when there is no poor tightening due to the imperfect area and thread is tightened over 2 with the tightened materials.
4. If the value is within the listed standard, the slip or damage to the screw may occur due to the screw or working condition.
5. Glossary (reference)

1) Nominal Size of the Screw

The screw is divided by its size. The mechanical screw is like M2, M3, M4 and the tap tight screw is like 2, 3, 4. The number indicates the diagonal of the screw.

2) Mechanical Screw

The thread is tapped to the fastened object in accordance to the pitch of the screw. This screw avoids the screw error and its torque value is easy to be controlled.

3) Tap tight screw

Without tapping the fastening object, the screw itself taps the thread (self-tap screw). Then, the screw, which does not make tapping chip, is called tap-tight screw.

4) Imperfect area

If thread the screw, the thread cannot tap to its head due to production reason. This area is called imperfect area.

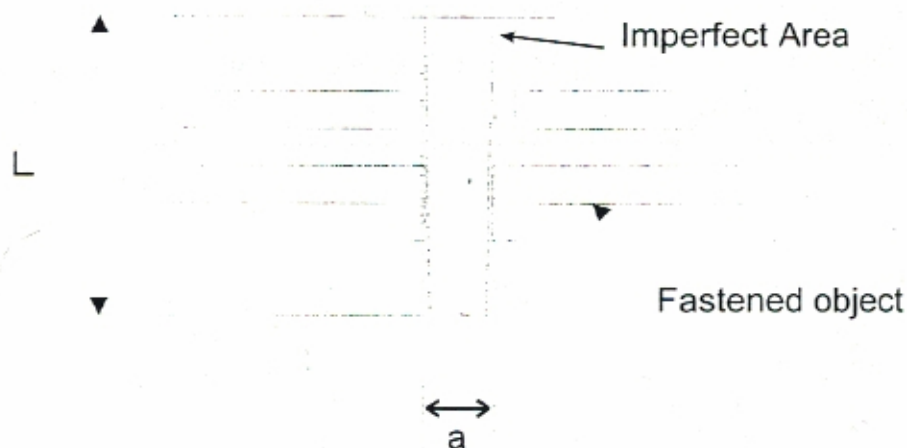

1. General torque standard (factory standard)

tighted diameter material (incl. Nut)	Aluminum (Al)	Steel (SPCC,SECC)	Resin (ABS,PS,Plastic) (L=Length of Screw)	
			L<10mm 4.0~8.0	10mm<L 6.0~10.0
Nominal Size 3	5.0~9.0	6.0~10.0	L<12mm 8.0~12.0	12mm<L 9.0~15.0
Size 4	8.0~12.0	9.0~15.0	L<20mm *	20mm<L 15.0~25.0
Size 5	*	15.0~25.0	*	
Size 6	*	20.0~30.0	*	
Size 8	*	Fix the CRT Refer to list 2	*	
Main use	fix the discharge plate (t>1.6)	bracket base, etc. sheet metal	fixing PCB (Size 3) FBT (Size 3) F.P (Size 4) to the Base or F.P	

2. Special Torque (Extraction the torque value which is out of the factory standard.)

Location	Model	Torque(kgf.cm)
Fixing CRT	MA-1560/61/62	40~45
	MA-1563	30~35
	MA-1783	25~31
	MA-1767/82	40~45
	MA-1762/64/66/80	45~55
	17 & 19" after MA-1570, 1790	37~43
	MA-2090/2091/2191/21A2/2192	40~50
	MA-1786/1794	30~36
	MS-2930	55~75
CP MAGNET	MA-1783	20
	MA-2171/2190/21B1	14~15
ASSY U202	MA-1767/82/83	8~10
BACK-COVER	MA-1767/82/83	13~19
	17 & 19" after MA-1570, 1790	
PCB-SW	MA-1570	5~9
	All the model after MA-1790	6~10
Power Earth	MA-2190/21A1	12
	All the model after MA-1790	
Equipping AC-INLET	All the model after MA-1790	8
Fixing LCD Panel	FA-1340/1561/1562/1563	5.5~7.5
Fixing ASSY MAIN-UNIT and TILT-STAND	FA-1340	13~15
Equipping ASSY PCB SUB-S*1	FA-1340	2.5~3.5
Equipping ASSY STAND-UNIT to PLATE-S*2	FA-1561	15~17
Equipping ASSY STAND-UNIT to SWIEBEL*3	FA-1880	16~20
Fixing STAY and ASSY CHASSIS	MS-2930	12~16
Fixing Q302 and radiator	MS-2930	2~3
Fixing the CASE	DH-1401	4~8

*1-3 Refer to the Disassembling drawing in the Service Manual for the detail.

*1 the torque value of screw No.13 which fixing the item No.G

*2 the torque value of screw No.p which fixes the item No.q

*3 the torque value of screw No.f which fixes the item No.8.

Section 1 – SPECIFICATION

CRT SPECIFICATION	1-1
ELECTRICAL SPECIFICATIONS	1-3
DISPLAY	1-4
DISTORTION	1-5
ITC PERFORMANCE	1-6
POWER SUPPLY	1-7
SIGNAL INPUT	1-8
RECOMMENDED SIGNAL TIMING CHART	1-9
ADJUSTMENT SPECIFICATIONS	1-10
MECHANICAL SPECIFICATIONS	1-14
AC CORD	1-15
CONFIGURATION	1-16
PACKAGING SPECIFICATIONS	1-18
CONNECTOR SPECIFICATIONS	1-21
CONDUCTIVE ALUMINIUM FOIL TAPE SPECIFICATIONS	1-23
CERTIFICATIONS & STANDARDS	1-24
RELIABILITY & SAFETY	1-25
OPERATING ENVIRONMENT SPECIFICATIONS	1-26
PACKAGING SPECIFICATIONS	1-27

CRT Specification

Type	A68KSM696X(B)
Size	29 inch 108° Deflection
Display Area	540mm×405mm
Trio Pitch	Horizontal: 0.79mm (Center), 0.97 mm (Edges) Vertical: 0.64 mm
Light Transmission:	49.0 % approx.
CRT Surface	Anti-Static Coating
Outline Drawing	*To view PDF file

Limitation of M.P.D.(Missing Phosphor Dots) for CRT

This limitation of M.P.D is applied to the effective screen (phosphor area). In the other screen area, limited are no other defects than scratches preventing the anti-static effective in aluminum foil taped area.

Width (mm)	Length (mm)	Depth
less than 0.05	No limit	The nail is not caught
0.06~0.13	50mm MAX.	
0.14~0.20	19mm MAX.	
more than 0.21	-	

CRT Outline Drawing

A68KSM696X(B)
Unit: mm

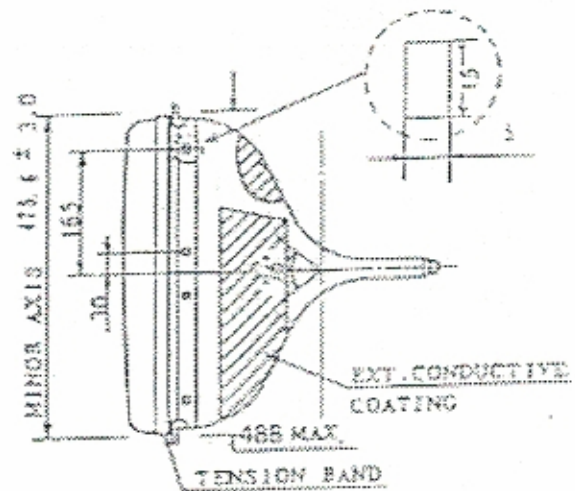
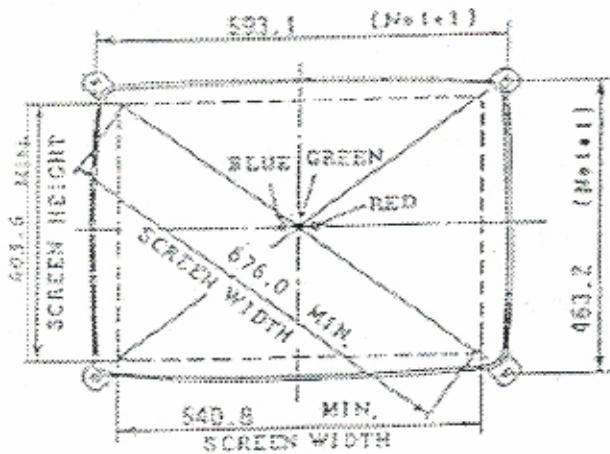
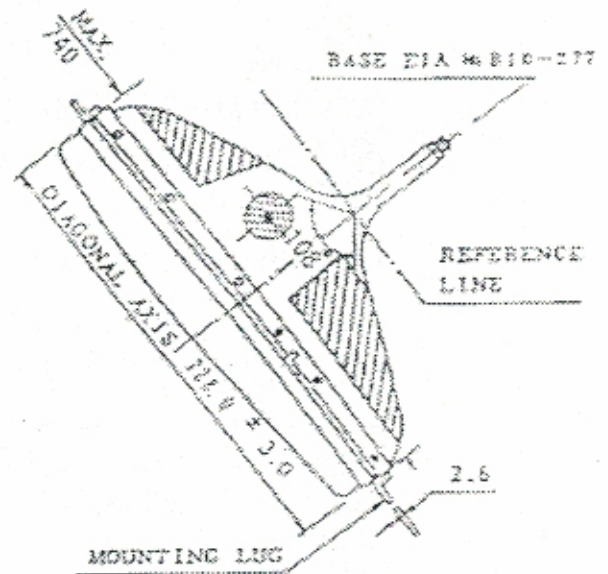
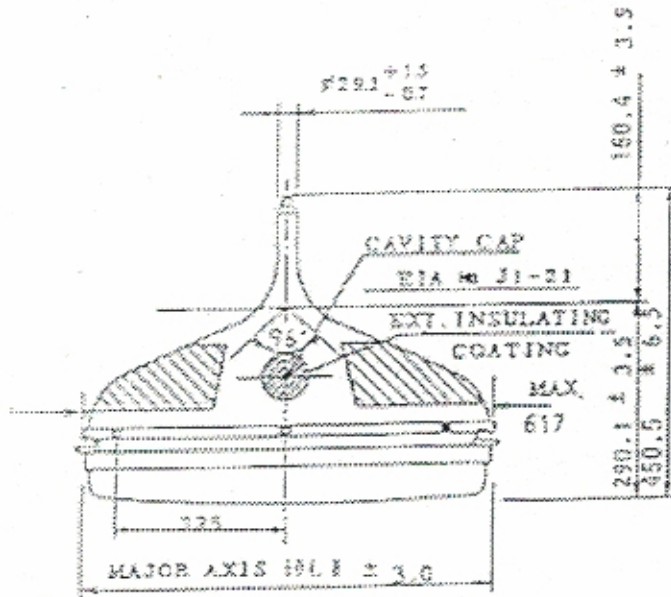

Face Curvature
Diagonal: R2390
Horizontal: R2400
Vertical: R2440

ELECTRICAL SPECIFICATIONS

Standard condition

Display

Distortion

ITC Performance

Power Supply

Signal Input

Recommended Signal Timing Chart

Adjustment Specifications

ELECTRICAL SPECIFICATIONS

All measurements are subject to the conditions below, unless otherwise specified.

Input signal	Recommended Signal Timing
Brightness	33% window pattern : 60 ft-L, white field pattern : 32 ft-L
Magnetic field	BH: 30 μ T, BV: 35 μ T (Japanese magnetic field)
Measurement	After warm up for at least 30 minutes
Display area size	540mm \times 405mm
Ambient temperature	20 C $^{\circ}$ ~30 C $^{\circ}$
Setting conditions	MS-2934-S/SW (TV Style) *The screen faces the east and the adjustment volumes and switches are in default settings, unless otherwise specified. MS-2934-SF/SFW/SN/SNW (Face Top) *The screen faces the top and the anode button of CRT faces west. Adjustment volumes and switches are in default settings, unless otherwise specified.

ELECTRICAL SPECIFICATIONS

Standard condition

Display

Distortion

ITC Performance

Power Supply

Signal Input

Recommended Signal Timing Chart

Adjustment Specifications

Display

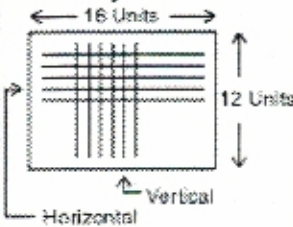
Items	Values	Condition
Scanning Frequency	Horizontal: 31.5 kHz \pm 500Hz Vertical: 55 ~ 65 Hz	
Retrace Time	Horizontal: 6.0 μ s max. Vertical: 1.1 ms max.	
Linearity 	Horizontal: \pm 10 % max. Vertical: \pm 8 % max.	To be measured with Cross-hatch patternAs obtained through following formula. $H = \frac{\{(X \text{ max. or } X \text{ min.}) - (X \text{ Ave.})\}}{(X \text{ Ave.})} \times 100V = \frac{\{(Y \text{ max. or } Y \text{ min.}) - (Y \text{ Ave.})\}}{(Y \text{ Ave.})} \times 100$
Center Resolution	640 \times 633 dots	As obtained through following formula.Center Resolution = Display area size / Center phosphor pitch
Video Bandwidth	Over 18MHz	The standard video output is 100kHz, 40Vp-p. The frequency is -3dB.

ELECTRICAL SPECIFICATIONS

Standard condition

Display

Distortion

ITC Performance

Power Supply

Signal Input

Recommended Signal Timing Chart

Adjustment Specifications

Distortion

Item	Values	Conditions
Trapezoidal	3.0 % max	To be measured based on JIS-C6101 and the CRT faces east
Barrel/Pincushion		
Tilt	2° max	

ELECTRICAL SPECIFICATIONS

Standard condition

Display

Distortion

ITC Performance

Power Supply

Signal Input

Recommended Signal Timing Chart

Adjustment Specifications

ITC Performance

Item	Value	Conditions
Jitters	To be invisible from the distance of 50 cm from CRT surface.	-
Color Purity	Conspicuous different colors shall not be recognizable with Red-field pattern against all directions after the internal degaussing.	To be degaussed in each direction.
Convergence	*Within a circle whose diameter is equivalent to 60 % of V. length of CRT: 1.5 mm max. *Within a circle whose diameter is equivalent to vertical length of CRT (excluding the above circle): 2.5 mm max. *Within CRT screen (excluding the above circles) : 3.0 mm max.	Max. deviation among RGB raster line center distances, either horizontal or vertical, shall not exceed the left listed value
White Balance	x: 0.285 ± 0.02 y: 0.285 ± 0.02 Color Temperature 9700K approx.	To be measured at center of a white-window pattern with Bright VR and Contrast VR in adjusted settings.
Focus	To be adjusted best.	-
Maximum brightness	60 ± 10 ft-L	Input signal 0.7 Vp-p To be measured with a white field pattern.

ELECTRICAL SPECIFICATIONS

Standard condition

Display

Distortion

ITC Performance

Power Supply

Signal Input

Recommended Signal Timing Chart

Adjustment Specifications

Power Supply

Item	Value	Conditions
Input current and voltage	100~120VAC±10%, 50/60Hz, 2A max.	-
In-rush current	72 A peak max	At 132 VAC
Power Consumption	110±16W	To be measured in default settings with a white field pattern.
Leakage current	1.0mA max 3.5mA max	at 100V, 60Hz at 120V, 60Hz

ELECTRICAL SPECIFICATIONS

Standard condition

Display

Distortion

ITC Performance

Power Supply

Signal Input

Recommended Signal Timing Chart

Adjustment Specifications

Signal Input

Sync Input Signal Form	H/V Composite, Negative or H/V Separate Sync, Positive/Negative
Video Input Signal Form	analogue, Positive
Scanning	Non-Interlace

ELECTRICAL SPECIFICATIONS

Standard condition

Display

Distortion

ITC Performance

Power Supply

Signal Input

Recommended Signal Timing Chart

Adjustment Specifications

Recommended Signal Timing Chart

31.50kHz

<Horizontal Timing Chart>

(unit: μ sec)

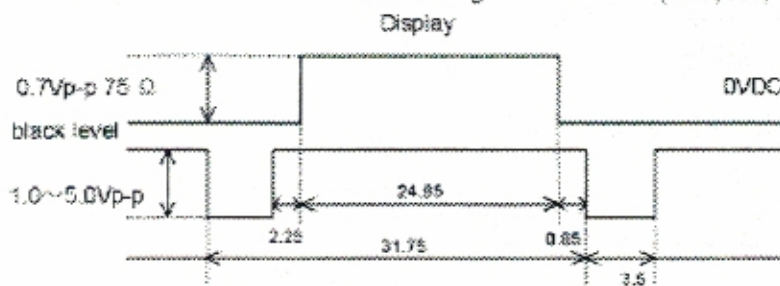

<Vertical Timing Chart>

(unit: msec)

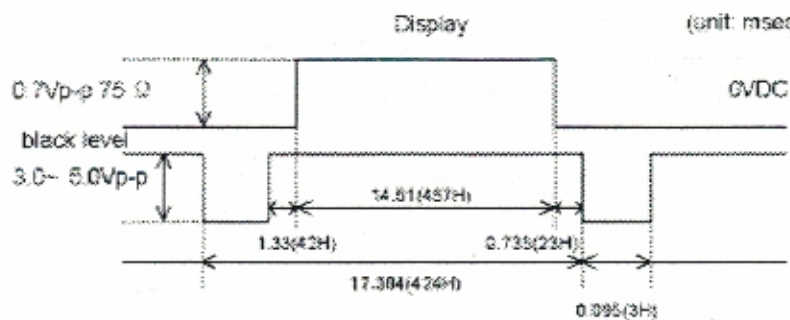

ELECTRICAL SPECIFICATIONS

Standard condition

Display

Distortion

ITC Performance

Power Supply

Signal Input

Recommended Signal Timing Chart

Adjustment Specifications

Adjustment Specifications

MS-2934-S/SW

MS-2934-SF/SFW

MS-2934-SN/SNW

* NAOMI(31k) Timing Chart

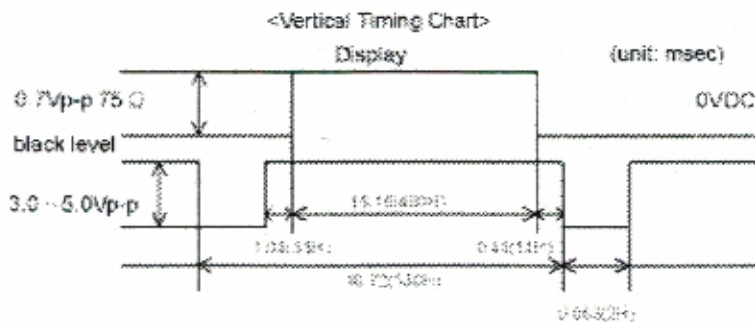
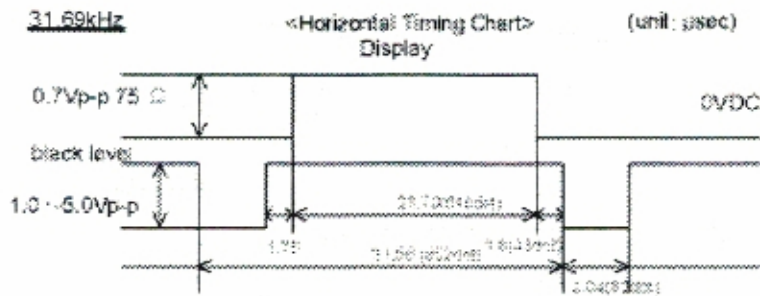

Adjustment Specifications (MS-2934-S/SW)

1. Adjustment Signal

- NAOMI(31k) supplied by SEGA or corresponded signal

2. Adjustment Specification

2.1 Display Size (Cross-hatch pattern) The screen shall face the east.

- The edge of the horizontal image shall be $5\text{mm} \pm 5\text{mm}$ from the edge of screen ("a" in the below figure)
- The edge of the vertical image shall be $5\text{mm} \pm 5\text{mm}$ from the edge of screen ("b" in the below figure)

(Size adjustment pattern)

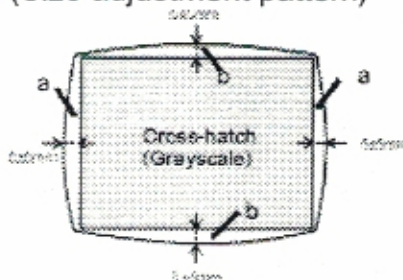

2.2 Scan Direction

The scanning shall start from left top corner when the monitor is set to face its anode button top.

(Example)



2.3 Display Position

To be centered.

2.4 White Balance (16 gradation pattern)

Conspicuous different white balance shall not be recognizable in low and high brightness part with 16 grayscale pattern. Low brightness level (1st gradation part) :

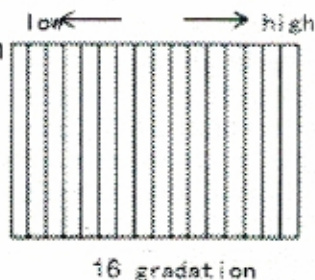

Adjustment Specifications (MS-2934-SF/SFW)

1. Adjustment Signal

- NAOMI(31k) supplied by SEGA or corresponded signal

2. Adjustment Specification

2.1 Display Size (Cross-hatch pattern) The sanode button shall face the west.

- The edge of the horizontal image shall be 5mm from the edge of screen ("a" in the below figure)
- The edge of the vertical image shall be 5mm from the edge of screen ("b" in the below figure)

(Size adjustment pattern)

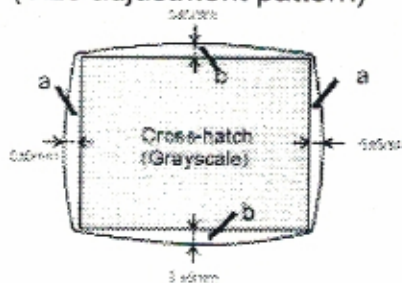

2.2 Scan Direction

The scanning shall start from right top corner when the monitor is set to face its anode button top. (Mirror)

The mirrored image will appear

(Example)



2.3 Display Position

To be centered.

2.4 White Balance (16 gradation pattern)

The brightness of the low part :12/255 at lowest part. The other parts: the lowest parts shall be disappeared at the 16 gradation pattern, $17n/255$ and $n=0\sim15$. Conspicuous different white balance shall not be recognizable in low and high brightness part with 16 grayscale pattern. Low brightness level (1st gradation part) :

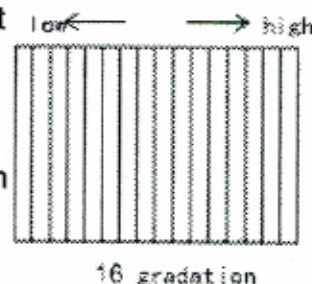

Adjustment Specifications (MS-2934-SN/SNW)

1. Adjustment Signal

- NAOMI(31k) supplied by SEGA or corresponded signal

2. Adjustment Specification

2.1 Display Size (Cross-hatch pattern) The Anode button shall face west.

2.1 Display Size (Cross-hatch pattern) The screen shall face the east.

- The edge of the horizontal image shall be 5mm5mm from the edge of screen ("a" in the below figure)
- The edge of the vertical image shall be 5mm5mm from the edge of screen ("b" in the below figure)

(Size adjustment pattern)

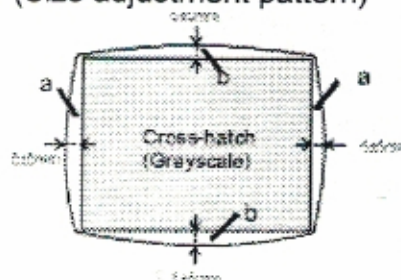

2.2 Scan Direction

The scanning shall start from left top corner when the monitor is set to face its anode button top.

(Example)



2.3 Display Position

To be centered.

2.4 White Balance (16 gradation pattern)

The brightness of the low part :12/255 at lowest part. The other parts: the lowest parts shall be disappeared at the 16 gradation pattern, $17n/255$ and $n=0\sim 15$ Conspicuous different white balance shall not be recognizable in low and high brightness part with 16 grayscale pattern. Low brightness level (1st gradation part) :

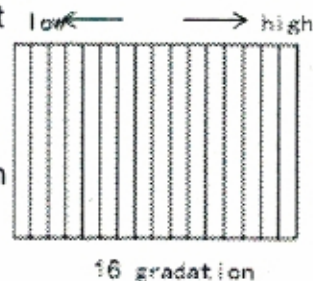

MECHANICAL SPECIFICATIONS

Adjustment Functions

AC CORD

Configuration

Packing specifications

Connector Specifications

Conductive Aluminum Foil Tape

Specifications

Adjustment Functions

PCB-VR *PCB-VR can be drawn out approx. 900mm from the monitor

- Brightness Adjustment (BRIGHT)
- Contrast Adjustment (CONTRAST)
- Horizontal Size Adjustment (H.SIZE)
- Horizontal Position Adjustment (H.POSI)
- Vertical Size Adjustment (V.SIZE)
- Vertical Position Adjustment (V.POSI)
- Red Gain Adjustment (R-GAIN)
- Green Gain Adjustment (G-GAIN)
- Blue Gain Adjustment (B-GAIN)

PCB-MAIN

- Trapezoidal Distortion Adjustment (TRAP)
- Pin-Cushion Distortion Adjustment (SPC)
- Vertical Linearity (V.LIN)
- Parallelogram Distortion Adjustment (PARA)
- Blue Cutoff Adjustment (B. CUT OFF)
- Green Cutoff Adjustment (G.CUT OFF)
- Red Cutoff Adjustment (R.CUT OFF)
- Sub Contrast Adjustment (SUB CONT)
- Focus Adjustment (FOCUS)

MECHANICAL SPECIFICATIONS

Adjustment Functions

AC CORD

Configuration

Packing specifications

Connector Specifications

Conductive Aluminum Foil Tape
Specifications

AC CORD

Exclusive AC CORD for SEGA.

MECHANICAL SPECIFICATIONS

Adjustment Functions

AC CORD

Configuration

Packing specifications

Connector Specifications

Conductive Aluminum Foil Tape

Specifications

Configuration

All of the dimensions, weights and angles below are reference values.

Dimensions (net)	625 mm (W) x 594 mm (H) x 488 mm (D)
Weight (net)	Weight (net) approx. 40.0 kg
Outline drawing	To View PDF file

MS-2934

: mm

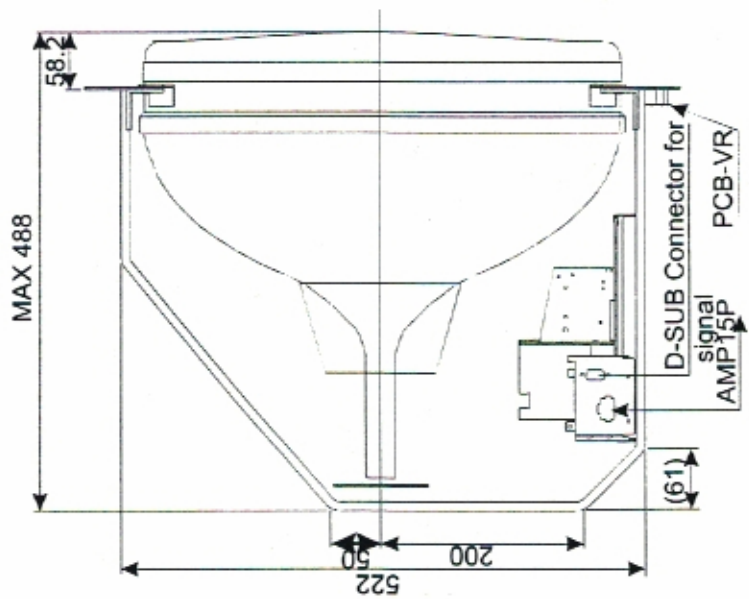
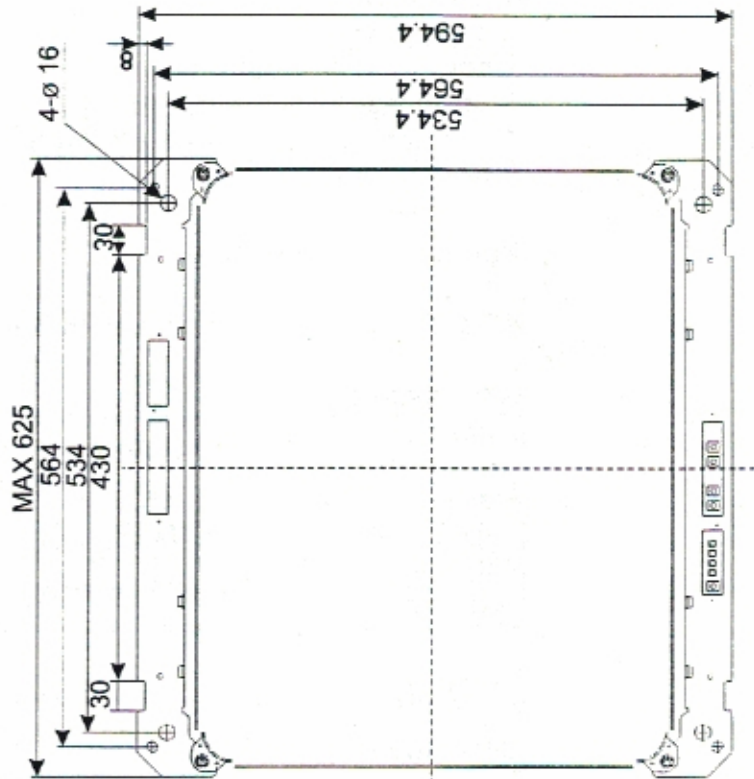
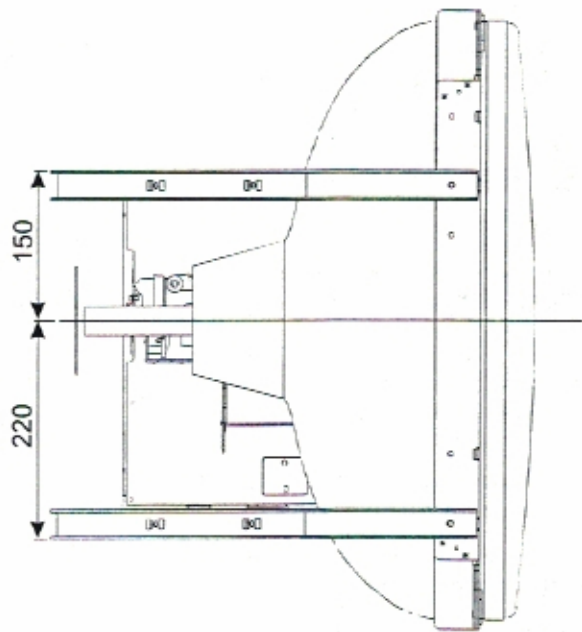

MECHANICAL SPECIFICATIONS

Adjustment Functions

AC CORD

Configuration

Packing specifications

Connector Specifications

Conductive Aluminum Foil Tape Specifications

Packing specifications

All of the dimensions and weight below are reference values.

(unit package)

Packing dimensions	756 mm (W) x 606 mm (H) x 728 mm (D)
Packing weight	approx. 45.0 kg
Stack limit	3 units (Maximum)
Packing drawing	PACKING Drawing

(pallet package)

Packing dimensions	1090 mm (W) x 670 mm (H) x 850 mm (D)
Packing weight	Packing weight approx. 108.0 kg
Stack limit	2 units (Maximum)
Packing drawing	PACKING Drawingf

Note)
1. After packing, seal the top with item 60 as the shape of "1"

(50)

Fig. 1 Packing case printing

GROUP	printing
A	
-S	200-5927
-SF	200-5927-01
-SN	200-5927-02

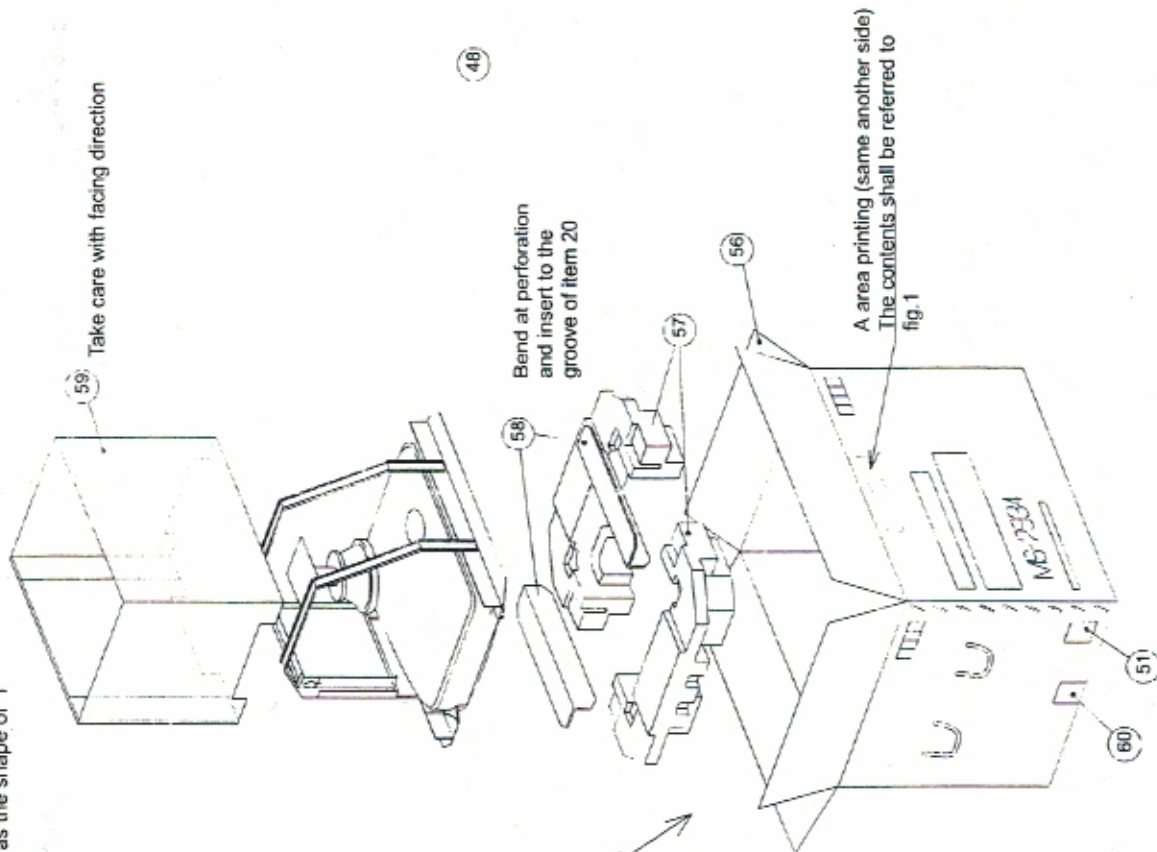

On putting. Do not catch the foreign material between CRT surface. Cover the whole CRT surface

MS-2934 ASSY SET PACKING DRAWING (2/2)
Unit package

CONFIDENTIAL

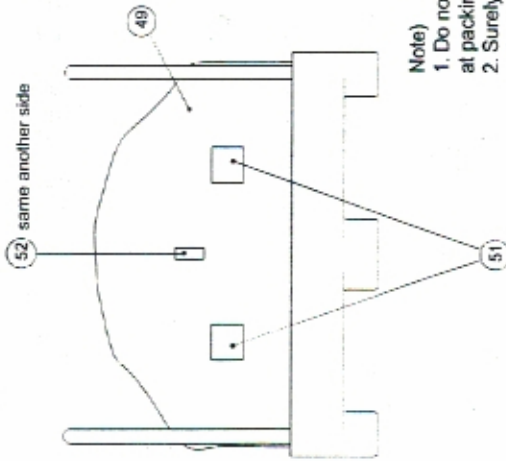
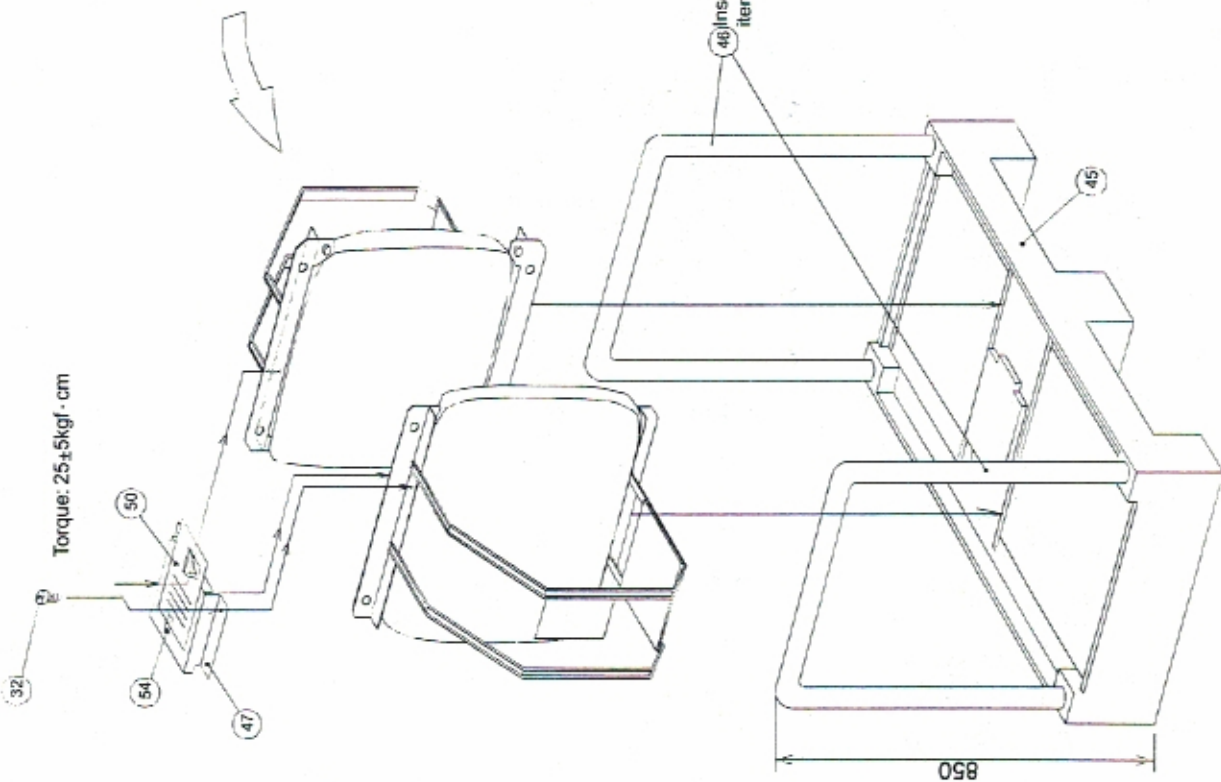
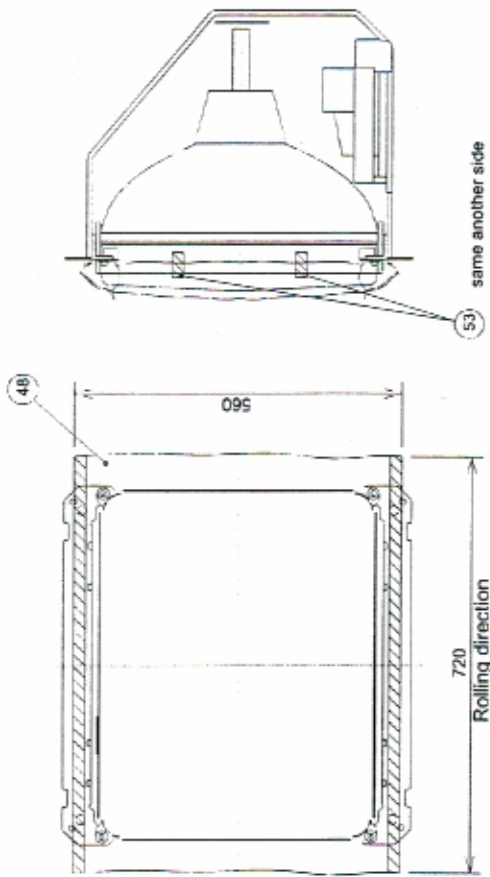

Note)
 1. Do not bump the CRT surface at packing.
 2. Surely cover with item 48 to the bottom and the surplus shall be insert under the STAY (BASE).

MS-2934 ASSY SET PACKING DRAWING (1/2)
Palette package

CONFIDENTIAL

MECHANICAL SPECIFICATIONS

Adjustment Functions

AC CORD

Configuration

Packing specifications

Connector Specifications

Conductive Aluminum Foil Tape Specifications

Connector Specifications

Connector Location

AMP UP Connector (176300-1)

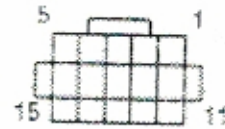

Pin #	Input signal	specification
1	N.C (No Connection)	-
2	N.C	-
3	N.C	-
4	N.C	-
5	N.C	-
6	AC Power Supply	100~120Vac±10%,50/60Hz
7	AC Power Supply	100~120Vac±10%,50/60Hz
8	N.C	-
9	DEM	SW shall be connected between 9pin and 10 pin.
10	DEM	SW shall be connected between 9pin and 10 pin.
11	N.C	-
12	N.C	-
13	N.C	-
14	N.C	-
15	N.C	-

Connector Pin Assignment Label

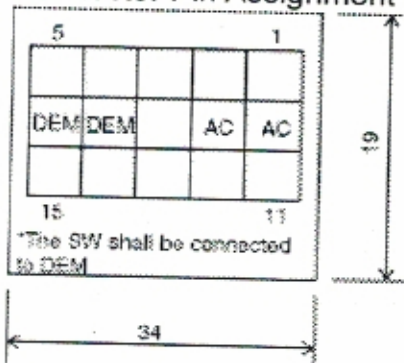

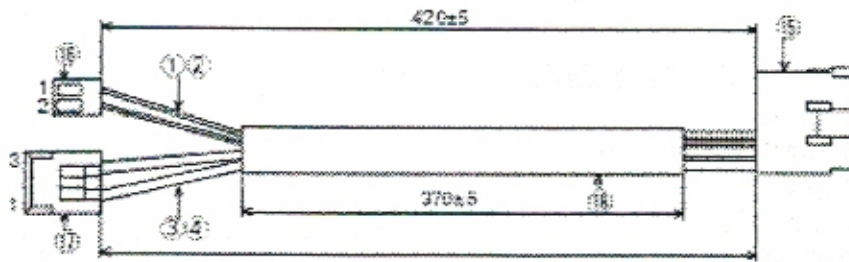

15. UP Connector		16 PHR-2 [to CN902]	
6	17-1 Black	1	15-9 Red
7	17-3 White	2	15-10 Orange
9	16-1 Red	17VHR-3 [to CN902]	
10	16-2 Orange	1	15-6 Black
		3	15-7 White
1~5, 8, 11~15 are opened		2 is opened	

4.6.3 D-SUB15 pin (mini) connector

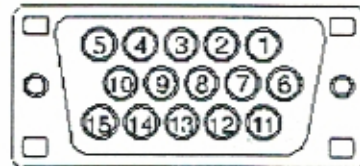

pin#	Input Singal	Specification
1	Red	Positive 0.7Vp-p/75Ohm
2	Green	
3	Blue	
4	N.C	-
5	Earth	Earth
6	Red Earth	
7	Green Earth	
8	Blue Earth	-
9	N.C	
10	Earth	
11	N.C	-
12	N.C	-
13	H.Sync or Composite Sync	Positive/Negative, Separate Sync, 3~5Vp-p Negative, Composite Sync, 1~5Vp-p
14	V.Sync	Positive/Negative, Separate Sync, 3~5Vp-p
15	N.C	-

MECHANICAL SPECIFICATIONS

Adjustment Functions

AC CORD

Configuration

Packing specifications

Connector Specifications

Conductive Aluminum Foil Tape

Specifications

Conductive Aluminum Foil Tape Specifications

Name	TERAOKA 830
Dimension (reference values)	
Taping	The aluminum foil tapes are put on to keep the surface of the panel and the integral implosion protection metal band conductive as follows (Since no problem is found in the mechanical and electrical performance.);

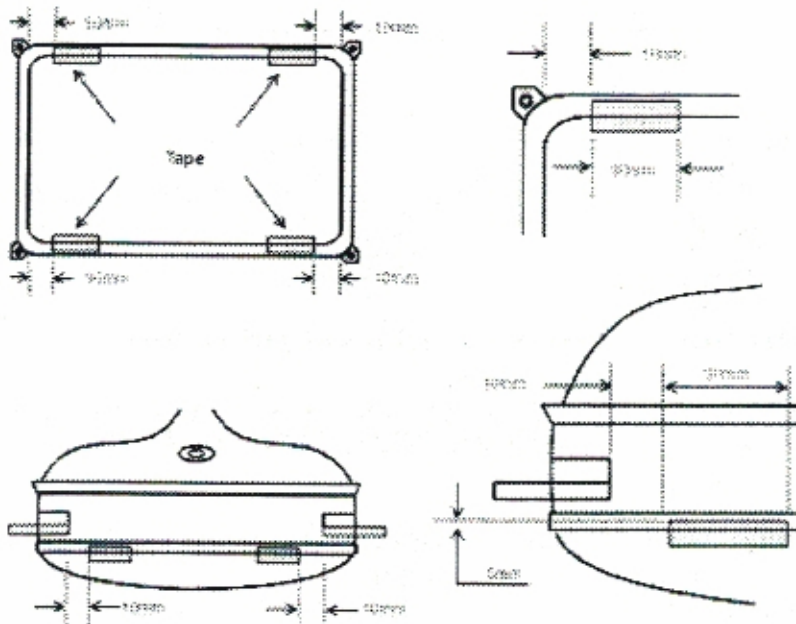

CERTIFICATIONS & STANDARDS

Certifications

Standard	Origin	Category				Mark
		Safety	EMI	Ergonomics	Others	
S-JQA	Based on Electrical Appliance & Material Control low (The 3rd clause, Table No.8 "applied apparatus")	Yes	-	-	-	Name Plate
TUV	EN60950: 1992+A1+A2+A3+A4+A11	Yes	-	-	-	Name Plate
CB	IEC60950: 1991+A1+A2+A3+A4	Yes	-	-	-	-
UL	UL 1950 2 nd	Yes	-	-	-	Name Plate
C-UL	CSA C22.2 No. 950 2 nd	Yes	-	-	-	Name Plate
DHHS (DNHW)	-	-	-	-	Yes (X-ray)	Name Plate
PTB*	-	-	-	-	Yes (X-ray)	-

Standards

Standards	Origin	Category				Mark
		Safety	EMI	Ergonomics	Others	
VCCI	VCCI Class A	-	-Yes	-	-	-
FCC	FCC Class A	-	-Yes	-	-	-

INSTALLATION INSTRUCTION FOR SAFETY REQUIREMENT

The monitor should be installed in following condition in order to meet the requirement of safety standard EN60950: 1992+A1+A2+A3+A4+A11

1. Power Supply

- a) The transformer which has double or reinforced insulation should be used between primary power source and the monitor.
- b) The rating of input power supply voltage should be 100-120Vac \pm 10%.

2. Ambient temperature

The ambient temperature around the monitor should be less than 40C°.

RELIABILITY & SAFETY

RELIABILITY

MTBF	20,000 hours at standard power input excluding CRT.*Values calculated according to the simplified "Parts Count Reliability Prediction" method as specified in MIL- HDBK-217F.
------	---

SAFETY

line noise resistance	No synchronized condition shall be detected when applying 500Vp-p pulse by using a noise simulator.
Undesired radiation	Based on Electrical Appliance & Material Control low Based on VCCI Class A (Excluded the Video Component)
High voltage label	To be pasted on the followings. <ul style="list-style-type: none">• Top of the anode cap• The anode lead• The focus and screen lead• The DY lead

OPERATING ENVIRONMENT SPECIFICATIONS

Ambient Temperature		Operation: 0°C~40°C Strage:-10°C~60°C(The inner temperature of the amusement machine should be designed below 40°C)
Ambient Humidity		Operation:30%~70%R.H. Non condensing Strage: 20%~80%R.H. Non condensing
Altitude		Operation: up to 3,000 m Shipping or Storage: up to 12,000 m
Vibration	(Ass'y chassis unit)	To be free from any damage to the circuits nor the appearance on 1 hour 1 G (face up : 0.5G) vibration test to be carried out under 5~100~5 Hz varying frequencies in every 10 minutes. To be validated along all three axes.
	(Unit package)	To be free from any damage on 30 minutes 1 G vibration test to be carried out under 5~100~5 Hz varying frequencies in every 10 minutes. To be validated along all three axes.
	(Pallet package)	To be free from any damage on 40 minutes (or 1 hour in up-down vibration only) 0.5 G vibration test to be carried out under 5~100~5 Hz varying frequencies in every 10 minutes. To be validated along all three axes.
Drop Test	(Unit package)	To be free from any damage on free drop from 40 cm height once.
	(Pallet package)	To be free from any damage on free drop from 15 cm height and on drop with support (10 cm) from 15 cm height once.

PACKAGING SPECIFICATIONS

Unit package

- PACKING Drawing (ASSY SET PACKING DRAWING)
- Parts List (ASSY SET)

Pallete package

- PACKING Drawing (ASSY SET PACKING DRAWING)
- Parts List (ASSY SET)

(The Number in the drawing is corresponded to the number in the parts list)

Section 2 – ADJUSTMENT

ADJUSTMENT CONTROL	2-1
TOOLS	2-5
SIGNAL (ANALOG)	2-6
ADJUSTMENT LOCATION	2-7
BEFORE ADJUSTMENT	2-9
ADJUSTMENT	2-10

Adjustment Control

To see Adjustment location (VR Position)(The number in the drawing is corresponded to the below numbers)

1. Contrast Adjustment (CONTRAST: VR283)
Adjust the contrast of the image.

2.Red Gain Adjustment (R-GAIN:VR280)
Turning clock wise darkens Red

3.Green Gain Adjustment(G-GAIN: VR281)
Turning clock wise darkens Green

4.Blue Gain Adjustment (B-GAIN FVR282)
Turning clock wise darkens Blue

5.Brightness Adjustment (BRIGHT: VR284)
Adjust the brightness of the image

6.H.Size Adjustment(H.SIZE: VR285)
Adjust the horizontal size of image

7.H.Position Adjustment (H.POSI: VR286)
Adjust the horizontal position of image

8.V.Size adjustment(V.SIZE: VR287)
Adjust the Vertical size of image

9.V.Position Adjustment(V.POSI FVR280)
Adjust the vertical position of image

10.V.Liniarity Adjustment (V.LIN:VR401)
Adjust the vertical linearity

11.Traezedoial Distortion Adjustment(TRAP:VR452)
Adjust the trapezoidal distortion

12.Side Pin Cushion distortion(S.P.C:VR450)
Adjust Side-pin-cushoin distortion

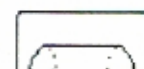
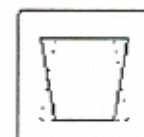
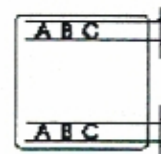
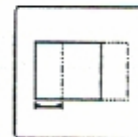
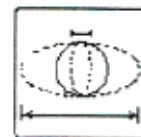
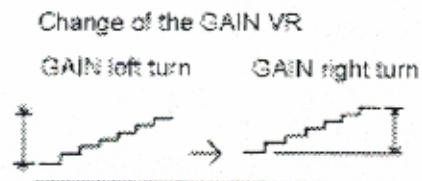

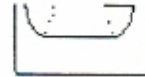

13.Parallelogram distortion (PARA:VR552)
Adjusts Parallelogram distortion

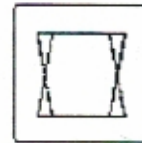

14.Blue Cutoff Adjustment(B-CUT OFF:VR203)
Turning Clockwise darkens Blue

Change of the CUT OFF VR
CUTOFF left turn CUTOFF right turn

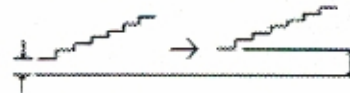

15.Green Cutoff Adjustment(G-CUT OFF FVR202)
Turning Clockwise darkens Green.





16.Red Cutoff Adjustment(R-CUT OFF:VR201)
Turning Clockwise darkens Red.

17.Sub Contrast Adjustment(SUB CONT: VR204)
Only if sufficient contrast is obtained with VR283, the screen contrast is adjusted with SUB.CONTRAST.

18.Focus Adjustment (FOCUS)
Adjust to get the best focus.

19.Screen Adjustment (SCREEN)
Adjust to just back raster disappearing.

20.21. Deflection Yoke Polarity Connectors

	20 CN401 normal	20 CN401 reverse
21 CN501 Normal	 <p>Normal screen</p>	 <p>Reversed Screen</p>
21 CN501 reverse	 <p>Mirrored Screen</p>	 <p>180o rotated screen</p>

20.CN401

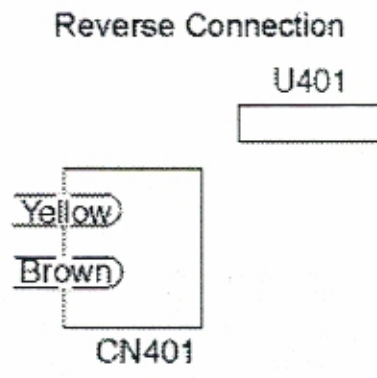
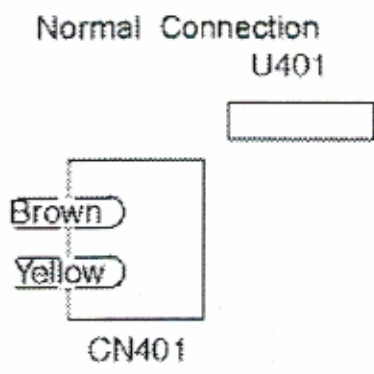

21. CN501

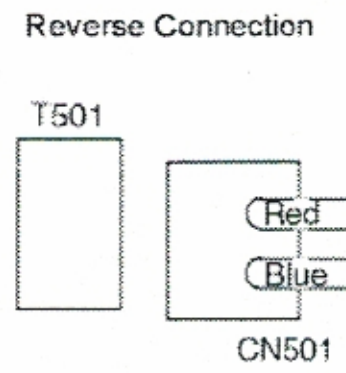
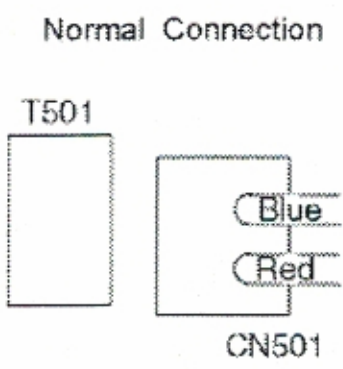

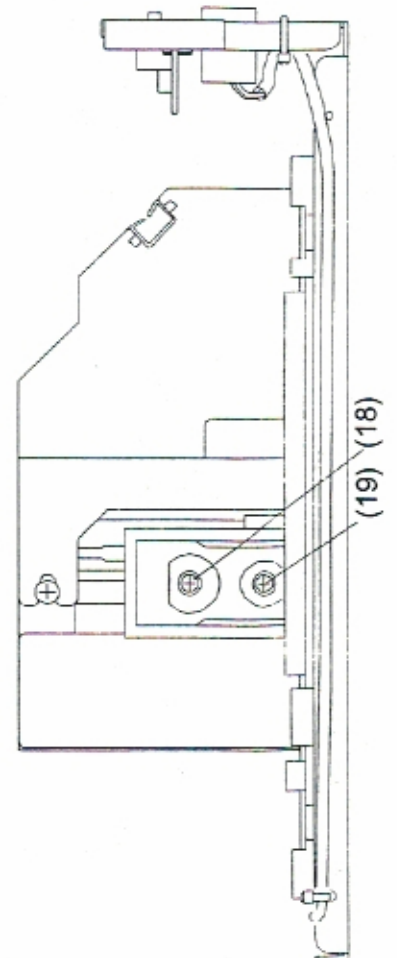
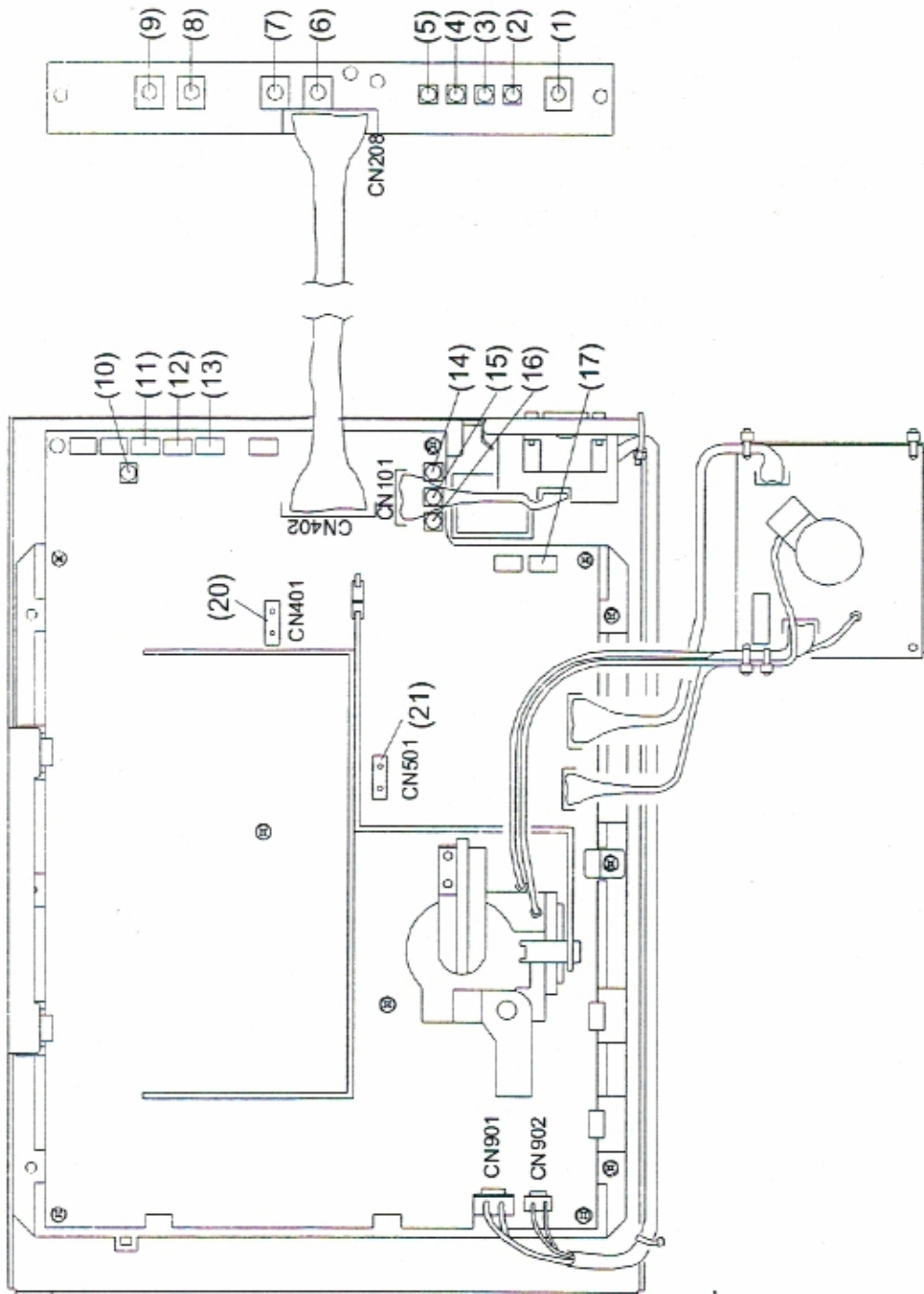

General Adjustment

Tools

Before starting general adjustment, the following tools are recommended to do tuning.

- Degaussing Bar
- Digital voltage meter.
- Frequency counter
- Signal Generator
- Brightness meter

Signal (analog Signal)

No	Source	Mode	fH fV	Dot Clock(iMHz)	Sync	BP	Display	Total	Sync V form (V)
1	Naomi (JAMMA31)	31k	31.69kHz 59.80Hz	27.00	3.04μs 3H	3.22μs 33H	23.70μs 480H	31.55μs 530H	Comp Nega 0
2	Size Limit 31k	31k	31.50kHz 60.00Hz	24.57	3.5μs 3H	2.73μs 43H	23.75μs 457H	31.75μs 525H	Comp Nega 0

Adjustment Location

Each adjustment VR shall be preset at the following location before turning ON.

VR	Name	PCB	Preset
VR951	{B-ADJ	MAIN	Center
VR283	Contrast	VR	Center
VR285	H.SIZE	VR	Center
VR286	H.POSI	VR	Center
VR287	V.SIZE	VR	Center
VR288	V.POSI	VR	Center
VR284	Bright	VR	Center
VR280	R.GAIN	VR	Center
VR281	G.GAIN	VR	Center
VR282	B.GAIN	VR	Center
VR201	R.CUT OFF	MAIN	counterclockwise max.
VR202	G.CUT OFF	MAIN	counterclockwise max.
VR203	B.CUT OFF	MAIN	counterclockwise max.
VR550	H.HOLD	MAIN	Center
VR204	SUB CONT	MAIN	Center
VR205	ABL	MAIN	Center
VR450	S.P.C	MAIN	Center
VR452	TRAPEZOIDAL	MAIN	Center
VR451	H.SIZE LIMIT	MAIN	Center
VR402	V.SIZE LIMIT	MAIN	Center
VR401	V.LIN	MAIN	Center
VR552	PARA	MAIN	Center
VR571	R.SHIFT	MAIN	clockwise max.
T501 (FBT)	SCREEN	MAIN	counterclockwise max.
T501 (FBT)	FOCUS	MAIN	Center

Adjustment Location for PCB-VR (seen from parts side)



Adjustment Location for PCB-MAIN

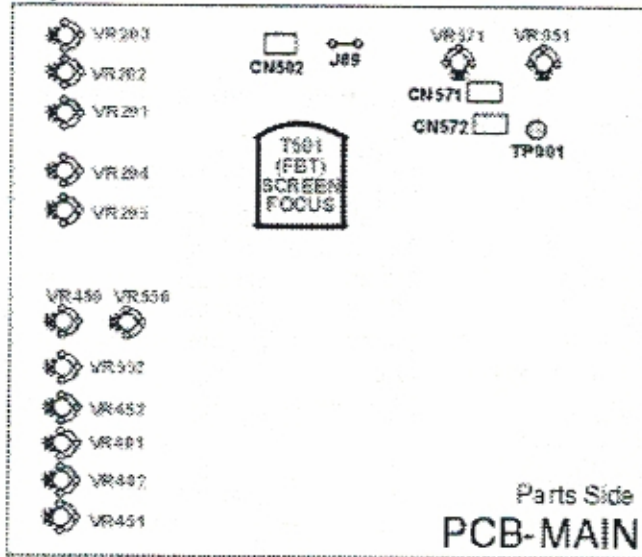

Before the Adjustment

- Before starting any adjustment, read and observe all safety precautions shown in "primary service manual".
- Make sure that all PCBs, chassis parts and connectors are in the right positions.
- Input voltage should be 100 VAC.
- Connect the GND terminal to the chassis base or the radiator at center of the PCB-MAIN.
- The CRT and the base should be degaussed.
- Make the pre-heat more than 30 minutes.
- The brightness in heat-running should be set 7 ft-L approx.
- The screen should face the east when adjusting, unless otherwise specified.
- The magnetic field should be set at the Japanese level (Bv: 0.35G, Bh: 0.3G)

WARNING

Do not short any position of the circuit while the monitor is in operation.



This will cause smoke, electric shock or damage to transistors, ICs or other parts or circuit in the unit. (Excluding the adjustment only when specified).

Input connector

Video Level	Video input connector
0.7Vp-p/75ohm	CN251

Adjustment

Adjust with facing the CRT surface to east. The face top one shall face its anode west.

<Whole Adjustment>

1	+B Adjustment
2	Preset
3	Degauss Circuit Confirmation
4	Horizontal Sync Adjustment
5	Focus Adjustment
6	Color Purity Adjustment
7	Convergence Adjustment
8	Raster H. Adjustment
9	H/V Size Limit Adjustment
10	V.Linearity Adjustment
11	Distortion Adjustment
12	Size and Position Adjustment
13	Color Adjustment
14	X-ray Protection Confirmation
15	Default Setting

1 +B Adjustment

	VR	How to adjust	measure Point	Signal
1	VR951	Set the Digital voltage meter at the TP901.	TP901	Non
2		Adjust 110 ± 0.2 VDC using the VR951.		

2 Preset

Turn the SCREEN VR slowly.

	VR	How to adjust	Signal
1	T501	Receive the signal. Adjust the SCREEN VR on the FBT so that back-raster slightly appears.	No.1 Cross-hatch
2		Adjust the FOCUS VR on the FBT to get the best focused image.	

3 Degauss Circuit Confirmation

	VR	How to adjust	Signal
1	CN902	Receive the signal. Confirm that degaussing can be effective after magnetizing.	No.1 Red-field

4 H Sync Adjustment

	VR	How to adjust	measure	Signal
--	----	---------------	---------	--------

VR	How to adjust	Point	Signal
1 VR550	Set the probe of the frequency counter at the DY Red lead. Adjust the VR701 on the PCB-MAIN to get the free-run frequency 31.5 ± 0.2 kHz.	DY red lead	Non

5 Focus Adjustment

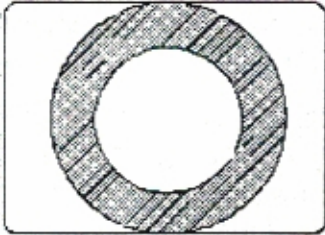
VR	How to adjust	Signal
1 T501	Receive the signal. Adjust with the FOCUS VR on the FBT to get the best focus in the below part. (See the below figure.) 	No.1

6 Color Purity Adjustment

VR	How to adjust	Signal
1 DY magnet	Receive the signal. Adjust by moving the DY back and forth to get the best purity. Keep the horizontal balance by opening the 2P magnet symmetrically.	No.1 RED-field
2	Adjust the purity in the corners of the screen with the magnets.	
3	Confirm if the satisfactory purity is obtained in all four directions after degaussing.	

7 Convergence Adjustment

The CRT surface shall face east and confirm in all direction. The anode of the Facetop Style should face the west when adjusting, and the all directions when confirming.

VR	How to adjust	Signal
1 DY magnet	Receive the signal. Adjust Yv with the magnet. (See the below figure.) 	
	Adjust Yv with the differential coil. (See the below figure.)	

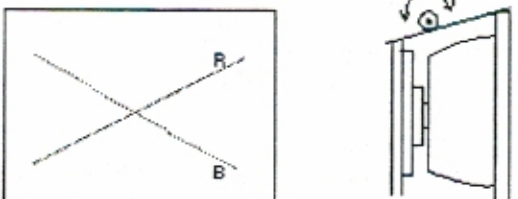
2		No.1 RED-field
3		If the misconvergence still appears in the corners of the screen, put the ferrite magnet into the space between the CRT and the DY.
4		After Adjustment, lock the ferrite sheet with silicone and lock the DY and CP magnet with paint.

8 Raster H. Adjustment

VR571 is preset clockwise max.. In the reverse connection, adjust with the VRs in the opposite direction.

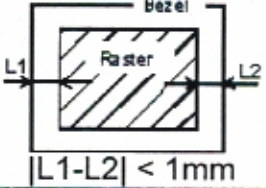
	VR	How to adjust	Signal
1	VR451	Receive the signal. Adjust the brightness so that the raster can appear slightly, and adjust the horizontal size to get the under-scanned image.	
2	VR571	Adjust the screen to set the horizontal raster position at the center of the bezel. When shifting the raster position to the left, insert the CN572 close to the CN571 (1pin). When shifting to the right, insert the CN572 close to the CN571 (3pin). (See the below figure.) 	No.1 black-field
3		Twist the two harnesses of the CN572 together and set them out of the PCB so that they should not touch the FBT.	

9 H/V Size Limit Adjustment

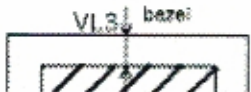
	VR	How to adjust	Signal
1	VR285 VR287	Receive the signal. Set the horizontal and vertical size at maximum.	
2	VR402	Adjust the screen size to get the same size of the edge between the image and the CRT screen. (See the below figure.) 	No.2 Cross-hatch

2 VR451

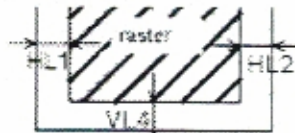

HL1, HL2, VL3, VL4 = $0 \pm 3\text{mm}$ (or within $0 \sim -8\text{ mm}$ if the adjustment is very difficult)

10 V.Linearity Adjustment

VR	How to adjust	Signal
1 VR288	Receive the signal and set the image at the vertical center. Adjust to get the desired linearity at the top and bottom of the crosshatch pattern.	No.1 Cross-hatch
2 VR401		

11 Distortion Adjustment

When adjusting the trapezoidal or/and parallelogram distortion, the CRT screen should face the east. As for the Facetop style, the anode should face the west.

VR	How to adjust	Signal								
1	Receive the signal. Confirm if the spec of the distortion meets the following value. <div style="text-align: center;"> </div> <table style="margin-left: auto; margin-right: auto;"> <tr> <td>$H1-H2$</td> <td>$< 7.0\text{ mm}$</td> </tr> <tr> <td>$H3-H4$</td> <td>$< 7.0\text{ mm}$</td> </tr> <tr> <td>$V1-V2$</td> <td>$< 5.0\text{ mm}$</td> </tr> <tr> <td>$V3-V4$</td> <td>$< 5.0\text{ mm}$</td> </tr> </table>	$ H1-H2 $	$< 7.0\text{ mm}$	$ H3-H4 $	$< 7.0\text{ mm}$	$ V1-V2 $	$< 5.0\text{ mm}$	$ V3-V4 $	$< 5.0\text{ mm}$	No.1 Cross-hatch
$ H1-H2 $	$< 7.0\text{ mm}$									
$ H3-H4 $	$< 7.0\text{ mm}$									
$ V1-V2 $	$< 5.0\text{ mm}$									
$ V3-V4 $	$< 5.0\text{ mm}$									
2 VR450	Adjust the side pincushion distortion so that the vertical lines are straight from top to bottom. <div style="text-align: center;"> </div> <p style="text-align: center;">Adjust the trapezoidal and</p>									

3	VR452	parallelotrammic distortion so that the length of the vertical lines are same from top to bottom.
		<p>Trapezoidal distortion</p>
4	VR552	Adjust the trapezoidal and parallelotrammic distortion so that the length of the vertical lines are same from top to bottom.
		<p>Parallelogram distortion</p>
5		If necessary, adjust the distortion, repeating steps 2~4.

12 Size and Position Adjustment

As for the Facetop style, the anode should face the west and confirm with all direction

VR	How to adjust	Signal
1	Receive the signal.	
2	Adjust the size and position to get the same size of the edge between the image and the CRT screen. (See the below figure.) HP1, HP2, VP3, VP4=10±4mm	No.1 Cross-hatch

13 Color Adjustment(White Balance and Brightness Adjustment)

VR	How to adjust	Signal
1	SCREEN VR Set the brightness at maximum with the BRIGHT VR clockwise max. to get the brightness 0.8 ± 0.2 ft-L	
2	VR201 VR202 VR203 Adjust R, G & B Cut Off to get a favorable white image. If a color analyzer is available, target color coordinates are as below. $x = 0.285 \pm 0.010$, $A_y = 0.285 \pm 0.010$ (1 or 3 volume shall be fixed)	No.1 black-field
3	If necessary, adjust the white balance repeating steps 2 and 3.	

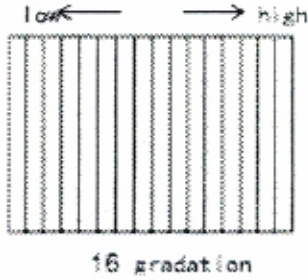
4	VR284	<p>Receive the grayscale signal. Adjust the brightness so that the raster, the first and the second gradation disappear.</p>  <p style="text-align: center;">16 gradation</p>	No.1 16 gradation pattern
		1st gradation part: 0/255, 2nd gradation part: 12/255 Other parts: 17 x (n-1)/255 n=1~16	
5	VR204	Receive the window signal. Adjust the window brightness (60.0 ± 2 ft-L).	
6	VR280 VR281 VR282	Adjust R, G & B Gain to get favorable white image. If a color analyzer is available, target color coordinates are as below. x = 0.285±0.010, Ay = 0.285±0.010	No.1 33% Window
7		If necessary, adjust the white balance repeating steps 5 and 6.	
8	VR205	Receive the white-field signal. Adjust the white-field brightness (32 ± 1 ft-L).	No.1 white-field

14 X-ray Protection Confirmation (Safety important works)

	VR	How to adjust	measure Point	Signal
1		Input 13.2 ± 0.1VDC to J89 with the DC power and make sure that the protector operation activates.	J89	No.1 Cross-hatch

15 Default Setting

	MS-2934-SF*	MS-2934-S*	MS-2934-SN*
CN501 (H.DY)	REVERSE	NORMAL	NORMAL
CN401 (V.DY)	NORMAL	NORMAL	NORMAL
Style	FaceTop	TV style	Face Top

Section 3 – TROUBLESHOOTING

NO SCREEN.....	3-1
RASTER APPEARS BUT NO IMAGE	3-3
SYNC IS NOT CORRECT	3-4

NOTE THAT THIS SHOULD ONLY BE ATTEMPTED BY QUALIFIED SERVICE PERSONNEL. FURTHERMORE, ANY WORK (QUALIFIED OR NOT) MAY INVALIDATE THE SERVICE WARRANTY.

No Screen

1. Fuse (F901) blown

Trouble in the Primary circuit

Check Q901, T901, BD901, D901, C905 and PTH901.

Recheck the input voltage when turning the power SW On.(90 ~ 132VAC)

2. High voltage comes up but no raster image

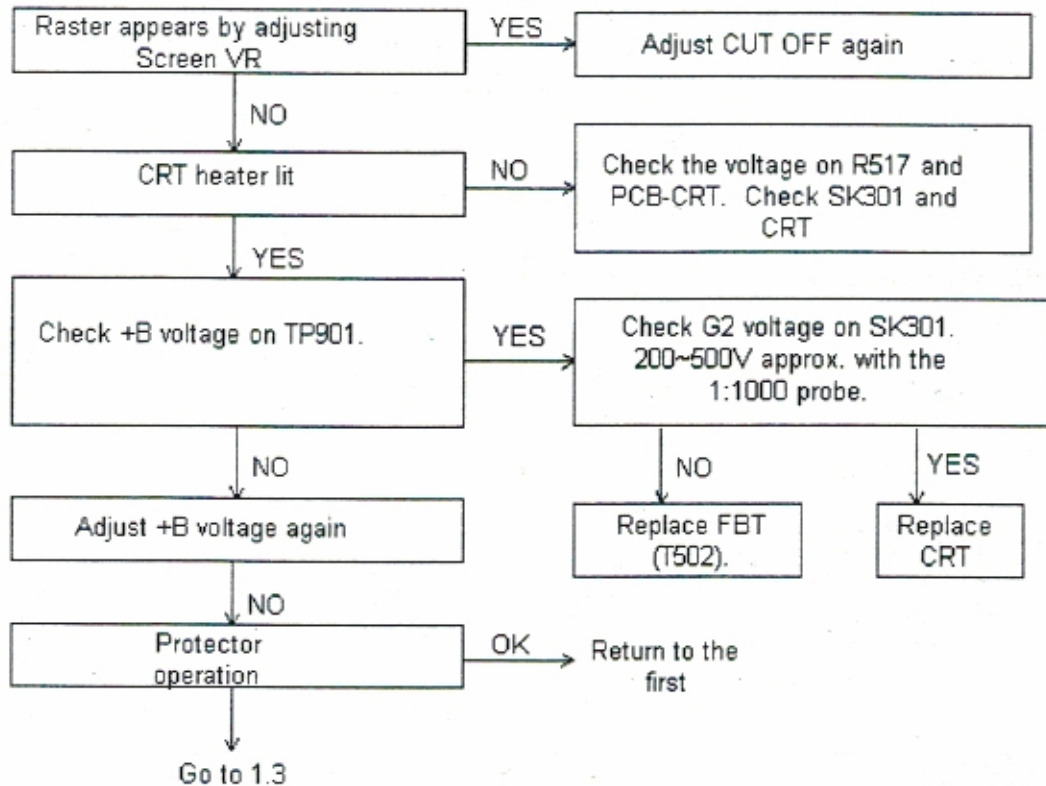

3. High voltage comes shortly

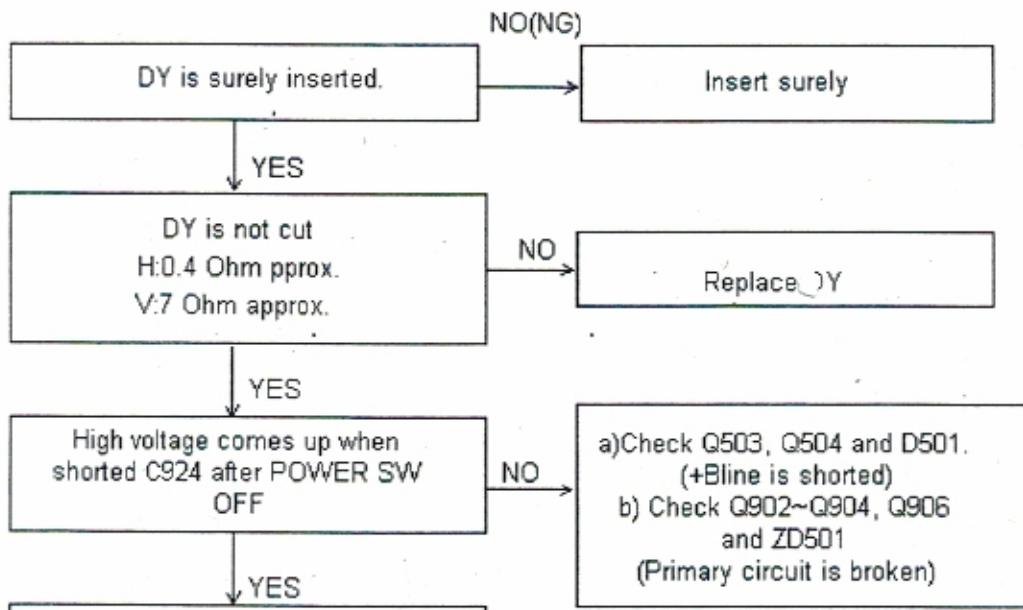

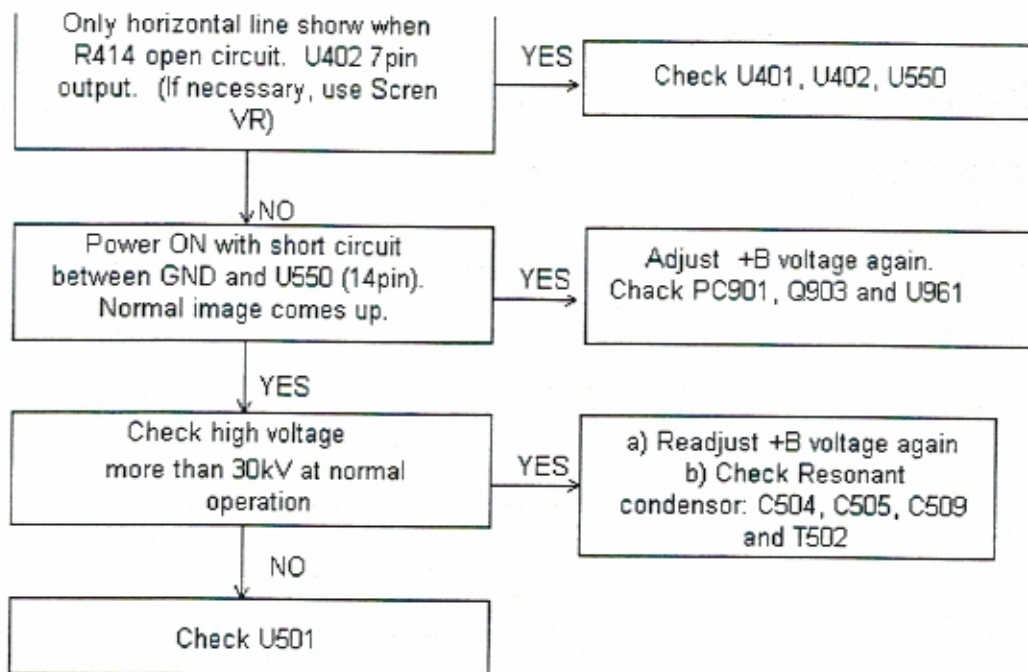

4.No high voltage but noise sounds

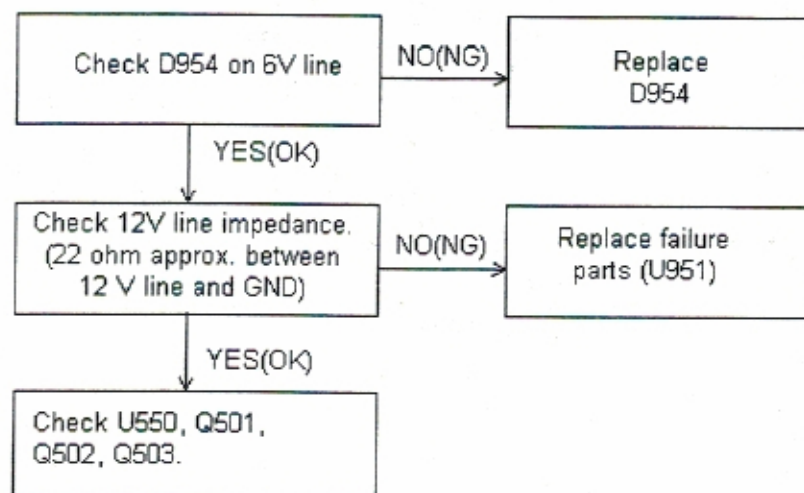

Raster appears but no image (or particular color is not displayed).

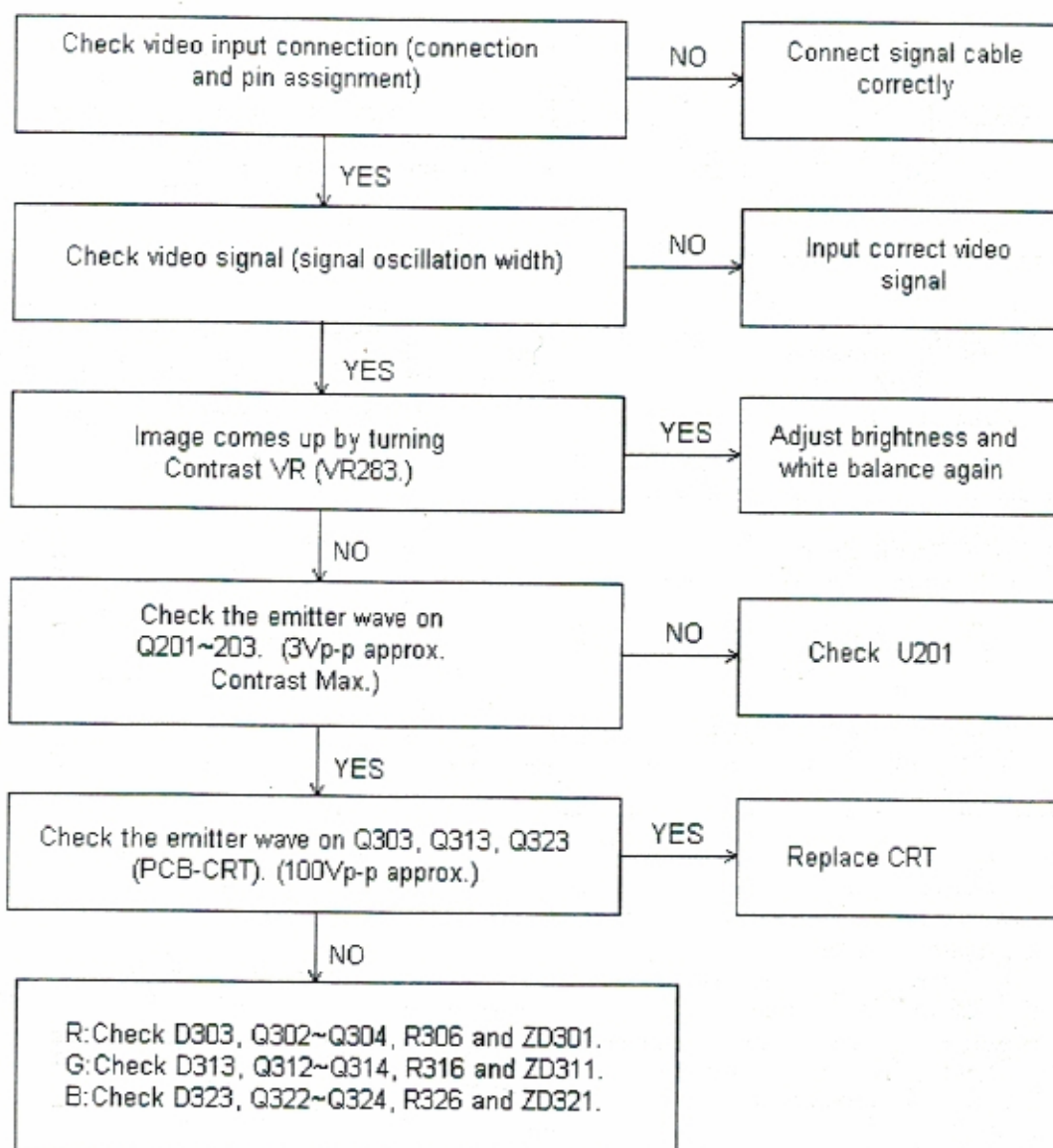

Sync is not correct.

1. Horizontal sync

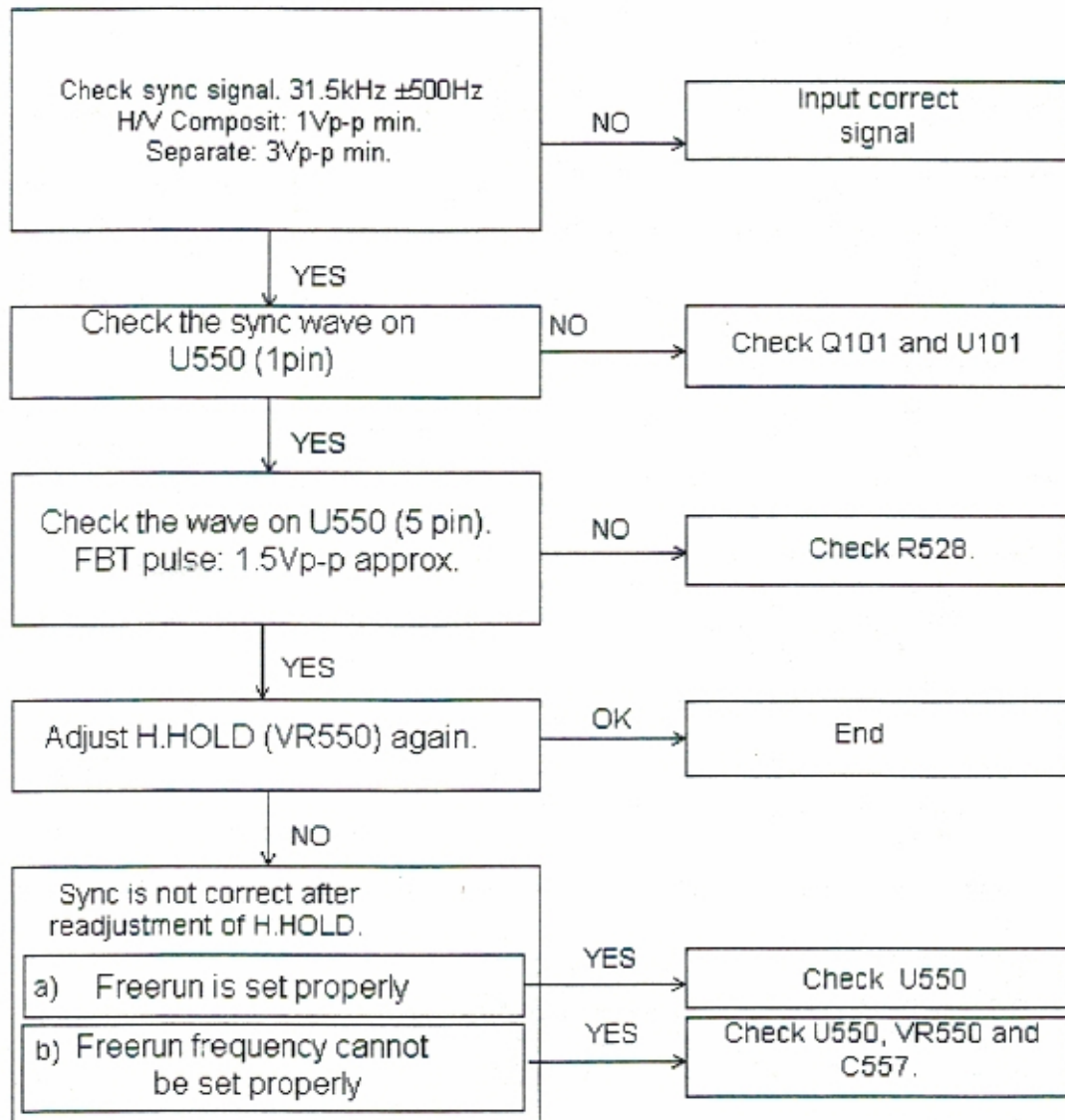

2. Vertical sync

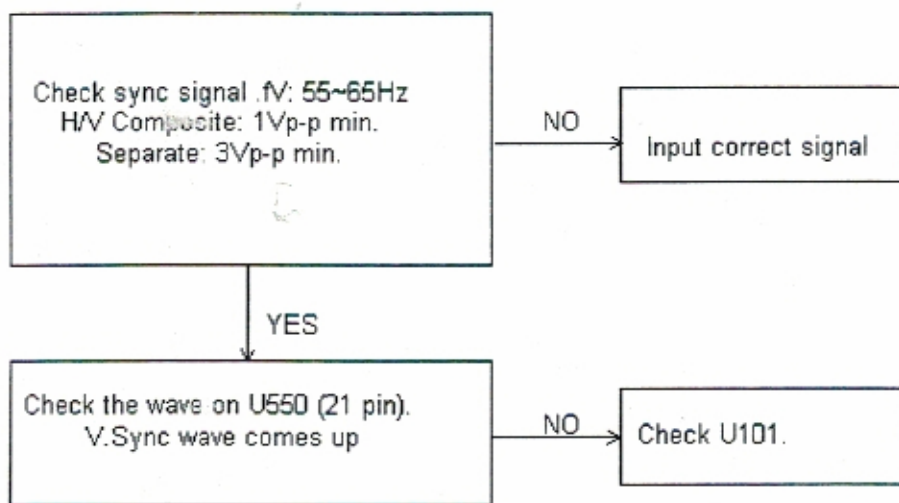

↓ YES

Check C542 and U550.

Notes

SEGA AMUSEMENTS EUROPE

Unit 2 Industrial Estate
Leigh Close
New Malden
Surrey
KT3 3NL
U.K.

UK Customers

Tel: +44 (0) 20 8336 1222

Fax: +44 (0) 20 8336 1715

European Customers

Tel: +44 (0) 20 8336 2256

Fax: +44 (0) 20 8942 1343

SEGA

